

SOPLADORES Y ASPIRADORES DE LÓBULOS GIRATORIOS

POSITIVE DISPLACEMENT BLOWERS AND EXHAUSTERS

por AIRE
for AIR

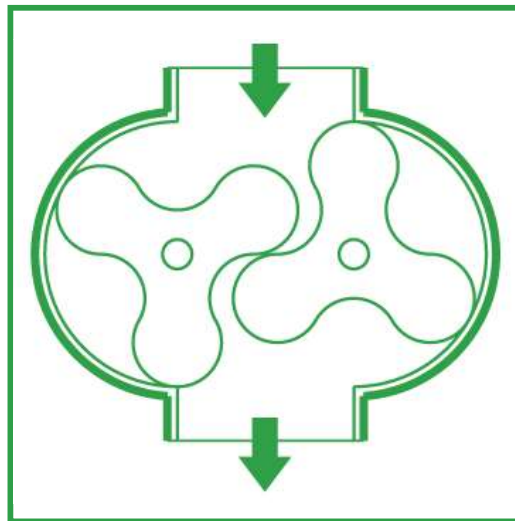

Este catálogo tiene únicamente fines informativos. Las prestaciones y características técnicas y dimensionales de los productos no pueden considerarse vinculantes. En la lógica de la mejora continua, el catálogo está sujeto a revisión. Para obtener información sobre la versión vigente, póngase en contacto con el servicio de ventas.
This catalogue is for informational purposes only. It should not be considered as a binding description of the products, their dimensions or their performance. In the logic of continuous improvement, the catalogue is subject to revision. Please contact our Sales Department for information on the version in force.

SOPLADORES Y ASPIRADORES DE LÓBULOS GIRATORIOS

POSITIVE DISPLACEMENT BLOWERS AND EXHAUSTERS

Principio de funcionamiento

Las máquinas de lóbulos giratorios MAPRO® están constituidas fundamentalmente por dos rotores de sección trilobulada, de ejes paralelos, que giran síncronos, en sentido contrario el uno al otro, dentro de un estator convenientemente perfilado y cerrado por fondos en los dos extremos.

El sincronismo de los rotores es generado por un par de ruedas helicoidales.

El gas a transportar es aspirado por el movimiento de los rotores en las cámaras que se crean entre el estator y los lóbulos, los cuales luego lo desplazan, con la rotación, hacia la boca de impulsión.

Las máquinas de lóbulos giratorios no comprimen el gas dentro del cuerpo de la máquina, pero la presión que se genera en la salida se debe únicamente a la resistencia del sistema conectado aguas abajo de la boca de impulsión.

Operating principle

MAPRO® Positive Displacement machines consist basically of a pair of Tri-lobe rotors, mounted on parallel shafts, rotating in opposite directions inside a properly shaped casing closed at the ends by side plates.

The two Tri-lobe rotors are synchronized by a pair of timing gears.

As the rotors rotate, air is drawn into the inlet side of the casing, is moved from the inlet to the outlet side by the free volumes between rotors and stator and finally is forced out of the outlet side against the connected system pressure.

The machines, being positive displacement type, do not develop pressure within the casing but the discharge pressure depends only upon the connected system resistance.

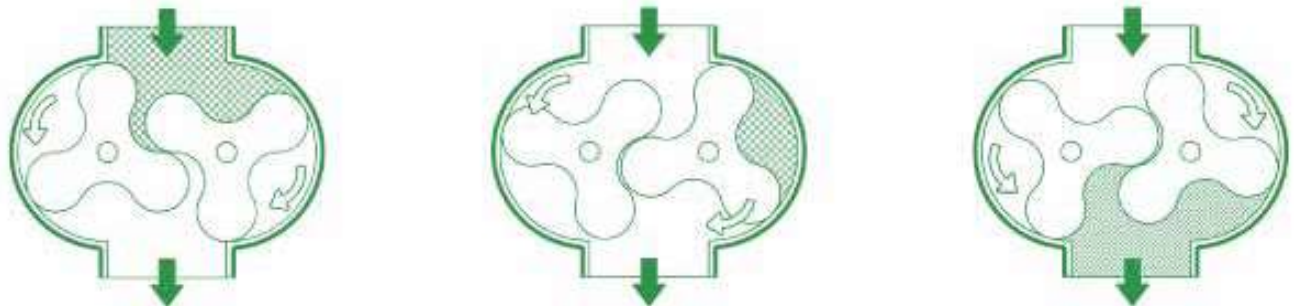

Notas técnicas de construcción del cuerpo de la máquina

- Estatores, rotores, fondos y tapas están hechos completamente de hierro fundido gris. Para el modelo ML175 las tapas son de aleación de aluminio para aumentar la eficacia del enfriamiento del aceite lubricante;
- los rotores están montados sobre ejes de acero;
- el engranaje de sincronismo está constituido por un par de ruedas helicoidales, con perfil evolutivo, de acero aleado, con superficie de los dientes cementada y rectificada;
- la estanqueidad del gas en los ejes de los rotores está asegurada por sellos de laberinto y segmentos;
- la lubricación de los transportes y del engranaje de sincronismo es por batido de aceite a través de discos esparcidor montado en los ejes de los rotores.

Technical and constructional features of the machine body

- Stators, rotors, side plates and covers are totally made of grey cast iron. The covers of model ML175 are made of aluminum alloy so that to increase the efficiency of the cooling of the lubricating oil;
- shafts are in carbon steel and rotors are shrinked on the shafts;
- the timing gears are helical type with involute profile and made of alloy steel, with hardened and ground teeth;
- sealing of the conveyed gas on the rotor shafts is assured by labyrinth seals and segments;
- bearings and timing gears are lubricated by the oil splashed by disks fitted on the rotor shafts.

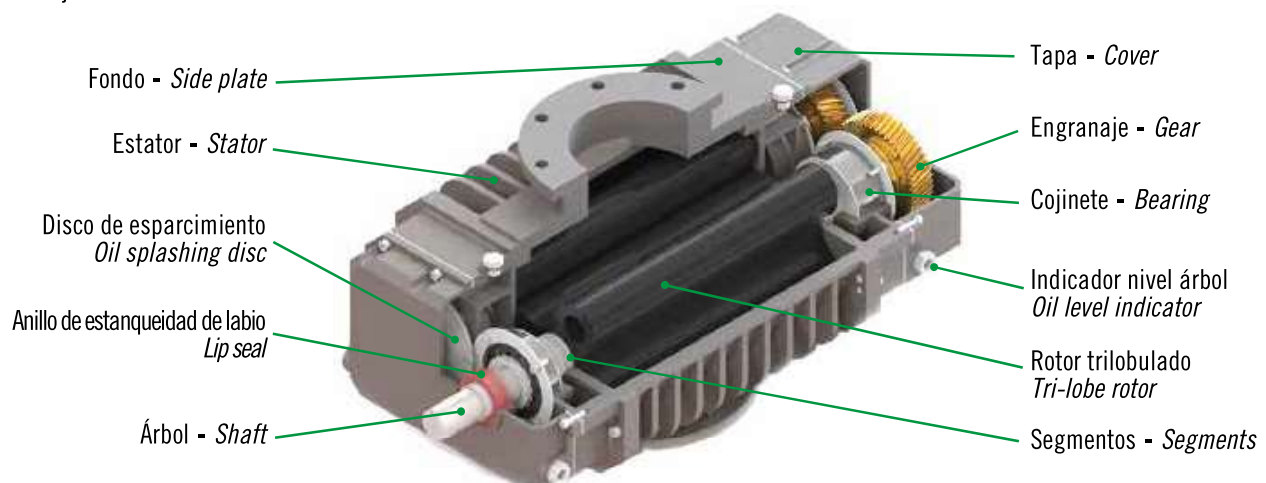

Notas técnicas de construcción de los grupos de compresión

Grupos estándar

- Los Sopladores de Lóbulos Giratorios MAPRO® se suministran normalmente con silenciador de impulsión integrado en la base de soporte y filtro silenciador de aspiración;
- la transmisión del movimiento entre la máquina y el motor eléctrico se realiza mediante correas y poleas; el tensado de las correas es automático gracias a la corredera basculante sobre la que está montado el motor eléctrico;
- los grupos estándar se completan con válvula de sobrepresión, válvula de retención, soportes antivibraciones, manguito flexible de conexión en impulsión y cárter de protección de la transmisión;
- a pedido están disponibles el manómetro y el indicador de obstrucción del filtro.

Grupos insonorizados

- Los grupos de compresión se pueden suministrar completos con cabina insonorizante;
- las cabinas tienen su propia base, sobre la que se fija el grupo estándar, y están equipadas con ventilador de extracción de aire, manómetro e indicador de obstrucción del filtro para el control rápido de las condiciones de funcionamiento de la máquina;
- opcionalmente están disponibles termómetros, presostatos y termostatos y los grupos pueden equiparse con un sistema para la carga y descarga rápidas del aceite lubricante.

Aplicaciones y ventajas

Los Sopladores de Lóbulos Giratorios MAPRO® se utilizan en todas aquellas aplicaciones en las que se requieren caudales más elevados que los de las máquinas de canal lateral y hasta 4200 m³/h, con una presión de impulsión de hasta 1000 mbar.

Las aplicaciones más típicas son:

- insuflación de aire en los tanques de oxidación de las plantas de tratamiento de aguas residuales;
- transporte neumático;
- insuflación de aire en suelos contaminados con el fin de estimular la biodegradación (Bioaspersión o Bioventilación)

Durante el funcionamiento de los Sopladores no hay partes entre ellos en deslizamiento. Por lo tanto, no hay fricción entre los lóbulos y entre los lóbulos y el estator y, por lo tanto, no es necesaria ninguna lubricación de las cámaras en las que se lleva a cabo el transporte de gas, que, por lo tanto, permanece totalmente libre de aceite lubricante.

Directivas Europeas

Los Sopladores de Lóbulos Rotativos MAPRO® responden a las normas generales previstas por las Directivas Europeas 2006/42 (Máquinas), 2014/35 (Baja Tensión), 2014/30 (Compatibilidad Electromagnética) y a las normas armonizadas aplicables.

Ejecución de conformidad con la Directiva 2014/34/UE (ATEX)



Los grupos estándar e insonorizados para aire también están disponibles en ejecución para Zonas 2 y 22 de la Directiva Europea 2014/34/UE (ATEX).

Technical and constructional features of the Packages

Standard Packages

- MAPRO® Positive Displacement Blowers are usually supplied complete with discharge silencer integrated in the supporting baseplate and with inlet silencer built-in into the inlet filter;
- the blowers are coupled to the electric motor via belt drives; thanks to the hinged motor support the belt drive tensioning is automatic;
- the standard packages are complete with pressure relief valve, non-return valve, antivibration base mounts, outlet flexible hose and safety drive guard;
- on request the packages can be supplied fitted with manometer and filter restriction indicator.

Soundproofed Packages

- The standard packages can be supplied complete with acoustic enclosure;
- the package is fixed on the baseplate of the acoustic enclosure; and besides the enclosure is equipped with air extraction fan, manometer and filter restriction indicator for a quick check of the working conditions of machine;
- on request the soundproofed packages can be supplied fitted with thermometers and temperature and pressure switches. And besides they could be equipped with system for the quick filling and draining of the lubricating oil.

Application and advantages

MAPRO® Positive Displacement Blowers are suitable for all those applications requiring considerably higher flow rate than that which can be achieved using side channel blowers and till 4200 m³/h, and with discharge pressure till 1000 mbar g. The most common fields of application are:

- air injection in the oxidation tanks of the wastewater treatment plants;
- pneumatic conveying;
- air injection in saturated soils to promote biodegradation of the contaminants (Biosparging or Bioventing).

There is no contact of the rotating parts during operation of the Blowers. There is therefore no friction between the two rotors and between the rotors and the stator and thus no internal lubrication is needed. The gas moving through the machine remains uncontaminated and completely oil-free.

European Directives

MAPRO® Positive Displacement Blowers meet the requirements of the European Directives 2006/42 (Machines), 2014/35 (Low Voltage), 2014/30 (Electromagnetic Compatibility) and of the applicable harmonised Standards.

Construction in conformity with the 2014/34/EU Directive (ATEX)



Standard and soundproofed packages for air are also manufactured in conformity to the requirements of the European Directive 2014/34/EU (ATEX) for Zones 2 and 22.



EL SISTEMA DE CONTROL MAPRO®SmartControl THE CONTROL SYSTEM MAPRO®SmartControl

MAPRO®SmartControl es un sistema especialmente desarrollado para el control y la gestión del funcionamiento de los sopladores de lóbulos MAPRO®.

Principales características

- Integración total del cuadro de automatización, del PLC, de los dispositivos de seguridad eléctricos y de la instrumentación dentro de la cabina de insonorización;
- Cableado de la instrumentación y de las seguridades eléctricas realizado directamente en fábrica;
- Pantalla “touch screen” de tipo industrial con gráficos e información de fácil comprensión;
- Regulación manual o automática de la frecuencia de alimentación del motor mediante control PID; la regulación se basa en las señales procedentes de un instrumento directamente montado en la máquina o instalado lejos en la instalación;
- Control y monitorización de los principales parámetros de funcionamiento de la sopladora;
- Fácil configuración de señales de E/S para configuraciones personalizadas;
- Registro de los eventos y del funcionamiento para análisis en tiempo real y para poder efectuar una fácil búsqueda de averías/anomalías;
- Registro de los mantenimientos y generación de una señal de alarma en cada “check point” alcanzado;
- Manual de uso OEM disponible en formato electrónico directamente en el PLC.

Protocolos de comunicación opcionales

A petición, el sistema MAPRO®SmartControl se puede suministrar con los protocolos de comunicación:

Profinet, RS-232, RS-485 y RS-422

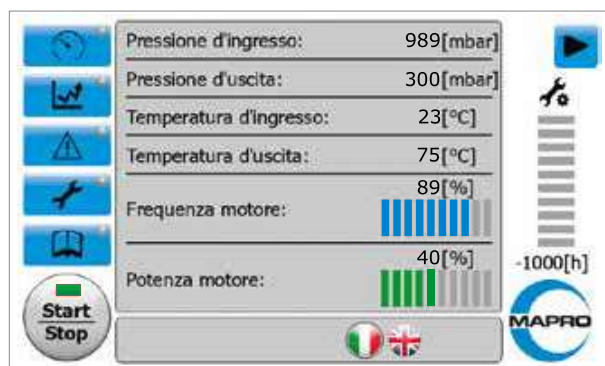

Instrumentación estándar

- Sensor de presión de impulsión;
- Sensor de presión de aspiración;
- Sensor de temperatura de impulsión;
- Sensor de temperatura de aspiración.

Instrumentación opcional

- Sensor de medición de oxígeno disuelto;
- Sensor temperatura aceite de lubricación engranajes de sincronismo y rodamientos;
- Sensor temperatura bobinado motor.

MAPRO®SmartControl is a system specifically developed for the management and control of MAPRO® PD blowers operation.

Main features

- Total integration in the acoustic enclosure of the automation control board, PLC, electrical safety devices and instrumentation;
- Wiring of the electrical safety devices and instrumentation carried out directly at MAPRO factory;
- Industrial-type “touch screen” display with easy-to-understand graphics and information;
- Manual or automatic regulation of the input frequency to the electric motor through PID controller; the frequency regulation is based on the signals from a sensor installed on board or far on the plant;
- Control and monitoring of the main operating parameters of the blower;
- Easy setting of the I/O signals for customized configurations;
- Recording of events and operation for real-time analytics and to make an easy search of faults / anomalies;
- Maintenance recording and generation of a warning signal when reaching each checkpoint;
- OEM instruction manual available in electronic format directly on the PLC screen.

Optional communication protocols

MAPRO®SmartControl system could be supplied, upon request, with the communication protocols:

Profinet, RS-232, RS-485 and RS-422



Standard instrumentation

- Outlet pressure sensor;
- Inlet pressure sensor;
- Outlet temperature sensor;
- Inlet temperature sensor.

Optional instrumentation

- Dissolved oxygen measurement sensor;
- Timing gears and bearings lubricating oil temperature sensor;
- Electric motor winding temperature sensor.

MAPRO®SmartControl: Lógica de control

El sistema MAPRO®SmartControl ha sido desarrollado para poder:

- regular en frecuencia la velocidad de rotación de la sopladora de manera simple y rápida, evitando así la instalación y programación de un “controlador” de automatización. El software permite el uso de los siguientes tres programas específicos de funcionamiento preestablecidos y completamente parametrizables:
 - programa de modulación de la velocidad de rotación del soplador en base a los “feedback” generados por instrumentación externa; el programa ha sido creado específicamente para el acoplamiento con una sonda de medición del oxígeno disuelto;
 - programa de modulación de la velocidad de rotación de la sopladora en base al “feedback” generado por la sonda de presión en impulsión, con el fin de evitar sobrecargas del motor eléctrico en caso de excesiva contrapresión de la instalación;
- gestionar las señales de alarma y de emergencia en función de la lectura de la instrumentación montada en la máquina, es decir, en función de:
 - superación del valor del umbral de presión en la impulsión de la sopladora;
 - superación del valor del umbral de depresión en la aspiración de la sopladora;
 - superación del valor del umbral de temperatura de impulsión de la sopladora;
 - superación del valor del umbral de temperatura en la aspiración de la sopladora (es decir, de la temperatura dentro de la cabina de insonorización).



MAPRO®SmartControl: Logic of control

MAPRO®SmartControl system has been developed for:

- *regulating the blower speed of rotation in a quick and easy way, thus avoiding the installation and programming of an automation controller. The software allows the use of the following three specific pre-set and fully parameterizable operating programs:*
 - *modulation program of the blower speed of rotation, based on the feedback from an external instrument; it has been specifically implemented for coupling with a dissolved oxygen measurement probe;*
 - *modulation program of the blower speed of rotation, based on the feedback from the outlet pressure sensor; it has been specifically implemented in order to prevent overload of the electric motor in case of too high system backpressure;*
- *handling alarm and emergency signals coming from the on board safety devices, that is:*
 - *the exceeding of the outlet pressure threshold value at the blower discharge;*
 - *the exceeding of the inlet pressure threshold value at the blower suction;*
 - *the exceeding of the outlet temperature threshold value at the blower discharge;*
 - *the exceeding of the inlet temperature threshold value at the blower suction (that is of the temperature inside the acoustic enclosure).*

Características generales del sistema eléctrico

- Alimentación cuadro de automatización: 230V 1F+N o 400V 3F+N 50Hz;
- Cableado realizado con cables apantallados para su uso en presencia de inversor;
- Entradas analógicas 4-20 mA para señales procedentes de instrumentación;
- E/S para retroalimentación y gestión de señales de emergencia procedentes del inversor;
- Seccionador de línea y bloqueo de puertas instalado directamente en el cuadro de automatización;
- Pulsador de emergencia al lado de la pantalla;
- Microinterruptores en las puertas que se abren de la cabina de insonorización para interrumpir la alimentación eléctrica en caso de apertura con la máquina en funcionamiento.

Electric system main features

- *Automation control board power supply: 230V 1ph + N or 400V 3ph + N 50Hz;*
- *Wiring with shielded cables to be used in electric systems including a VFD;*
- *4-20 mA inputs, for the analogue signals coming from the instrumentation;*
- *I/O for feedback and for the management of emergency signals from the VFD;*
- *Line breaker and doors interlock directly installed on the automation control board;*
- *Emergency mushroom fitted on the side of the “touch screen” display;*
- *Micro-switches on the doors of the acoustic enclosure that can be opened for maintenance, so that to cut off the power supply when opening a door with blower in operation.*

US800 – Unidad de monitoreo integrada

Descripción del dispositivo

MAPRO US800 es un dispositivo de monitorización electrónica, cuyo objetivo principal es la lectura y conversión de 4 señales de corriente analógicas (4-20 mA).

El dispositivo permite establecer umbrales para cada entrada analógica, activar indicaciones en la pantalla y gestionar una señal digital de emergencia externa.

La señal de emergencia generada se puede conectar a sistemas más complejos (PLC) en la cadena de control del sistema, o se puede cablear directamente a dispositivos eléctricos que cortan inmediatamente el voltaje de la máquina.

Configuración del panel integrado

El dispositivo está configurado como una unidad completamente cableada, con un botón de parada de emergencia. El conjunto está montado en un panel de aluminio que soporta todos los componentes electrónicos.

En la configuración estándar se incluyen los siguientes elementos:

- dispositivo de monitoreo MAPRO US800;
- Botón de parada de emergencia;
- Transformador AC/DC para la alimentación de los componentes electrónicos;
- Seccionador modular con fusible de protección;
- Bloque de terminales modular 230 V para un fácil cableado a la línea de alimentación.

Entradas y salidas en configuración estándar y sensores opcionales

Sensores estándar

La configuración estándar incluye los siguientes sensores establecidos en los campos de conversión correspondientes:

sensor de presión de impulsión: sensor de elementos cerámicos con transmisor de salida (corriente 4-20 mA cc), rango de medición [0;1000] mbarg;

sensor de temperatura de salida: resistencia eléctrica PT100 con salida del transmisor (corriente 4-20 mA dc), rango de medición [-20;150] °C.

Sensores opcionales

Como opción, se pueden incluir los siguientes sensores en el paquete instalado:

sensor obstrucción filtro aspiración flujo / Depresión aspiración: sensor de elementos cerámicos con transmisor de salida (corriente 4-20 mA cc), rango de medición [-1000;0] mbarg;

- sensor de temperatura de entrada / temperatura de la carcasa: resistencia eléctrica PT100 con salida del transmisor (corriente 4-20 mA dc), rango de medición [-20;70] °C.

US800 - Control Unit integrated

Description of the device

MAPRO US800 is an electronic monitoring device, whose main purpose is reading and converting 4 analogue current signals (4-20 mA).

The device allows for thresholds to be set for each input, which trigger display indications and an external emergency digital signal.

The emergency signal thus generated can be connected to more complex systems (PLC) upwards in the system control chain, or can be directly wired to electrical devices that immediately de-energize the driven machine.

Integrated panel configuration

The device can be configured as a fully cabled unit, complete with an emergency stop push-button.

The assembly is mounted on an aluminum panel that supports all of the electronic components.

The following items are included in the present configuration:

- MAPRO US800 monitoring device;
- Emergency stop push-button;
- AC/DC transformer to power the electronic components [Omron S8VK-C06024];
- Modular disconnecter with protection fuse [Schneider Electric A9N15646] 230 V terminal block for easy cabling to the power line.



Inputs and outputs in standard configuration and optional sensors

Standard sensors

Standard configuration comprises the following sensors set to the corresponding conversion ranges:

- outlet flow pressure sensor: ceramic element sensor with output transmitter (4-20 mA dc current), measuring range [0;1000] mbarg;

- outlet flow temperature sensor: PT100 electrical resistance with output transmitter (4-20 mA dc current), measuring range [-20;150] °C.

Optional sensors

As an option, the following sensors can be included in the installed package:

- Flow intake filter clogging sensor / Intake vacuum Ceramic element sensor with output transmitter (4-20 mA dc current), measuring range [-1000;0] mbarg;

- Inlet flow temperature sensor / Enclosure temperature PT100 electrical resistance with output transmitter (4-20 mA dc current), measuring range [-20;70] °C.



Campo de uso

Los diagramas a continuación muestran indicativamente los campos de uso “flujo-presión” de los diferentes modelos de máquina de la Serie ML, que funcionan como sopladores.

Los campos de uso se refieren al aire atmosférico en las condiciones de aspiración de 20°C y 1013 mbar abs.

En las tablas de las páginas siguientes se detalla el rendimiento de cada modelo de soplador.



Range of duty

The diagrams below show, as an indication only, the duty range “flow rate – outlet pressure” for the ML Series models, operating as blowers.

The values of the diagrams refer to atmospheric air at the suction conditions of 20°C and 1013 mbar abs.

The tables on the next pages give the detailed performance of each blower model.

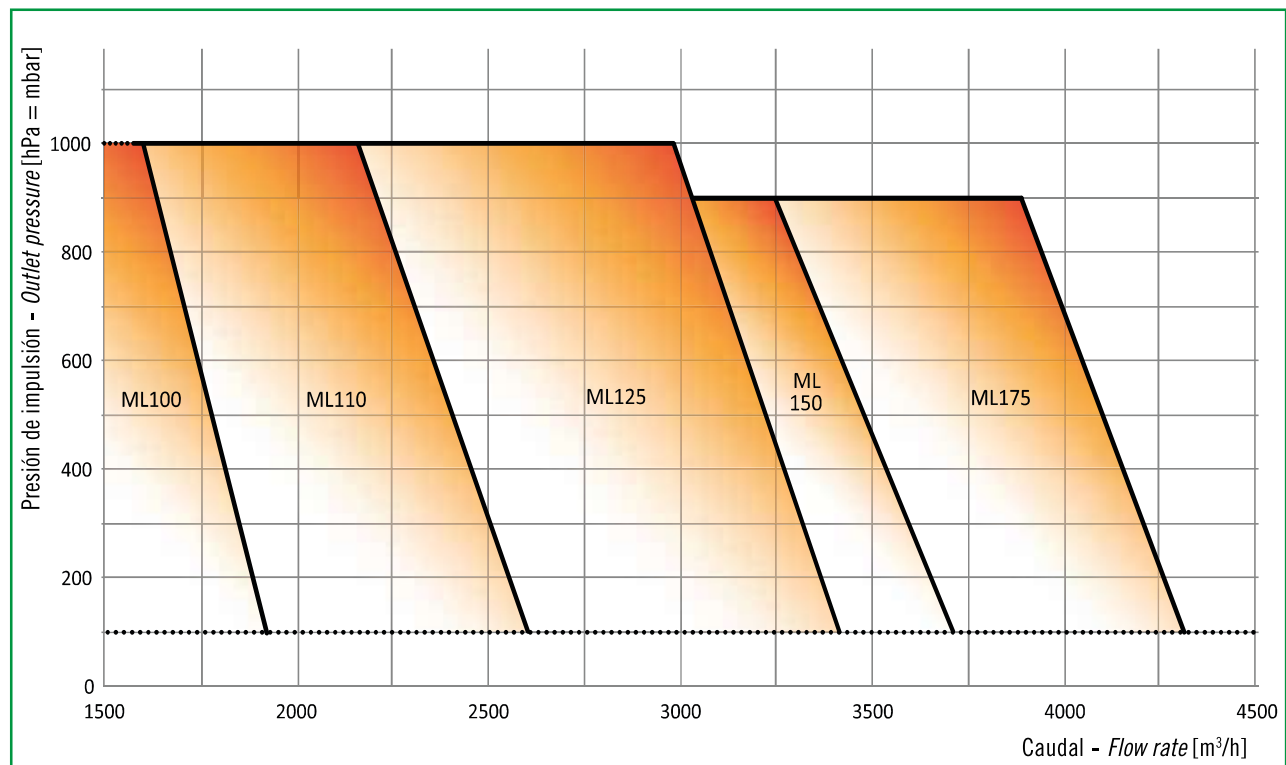
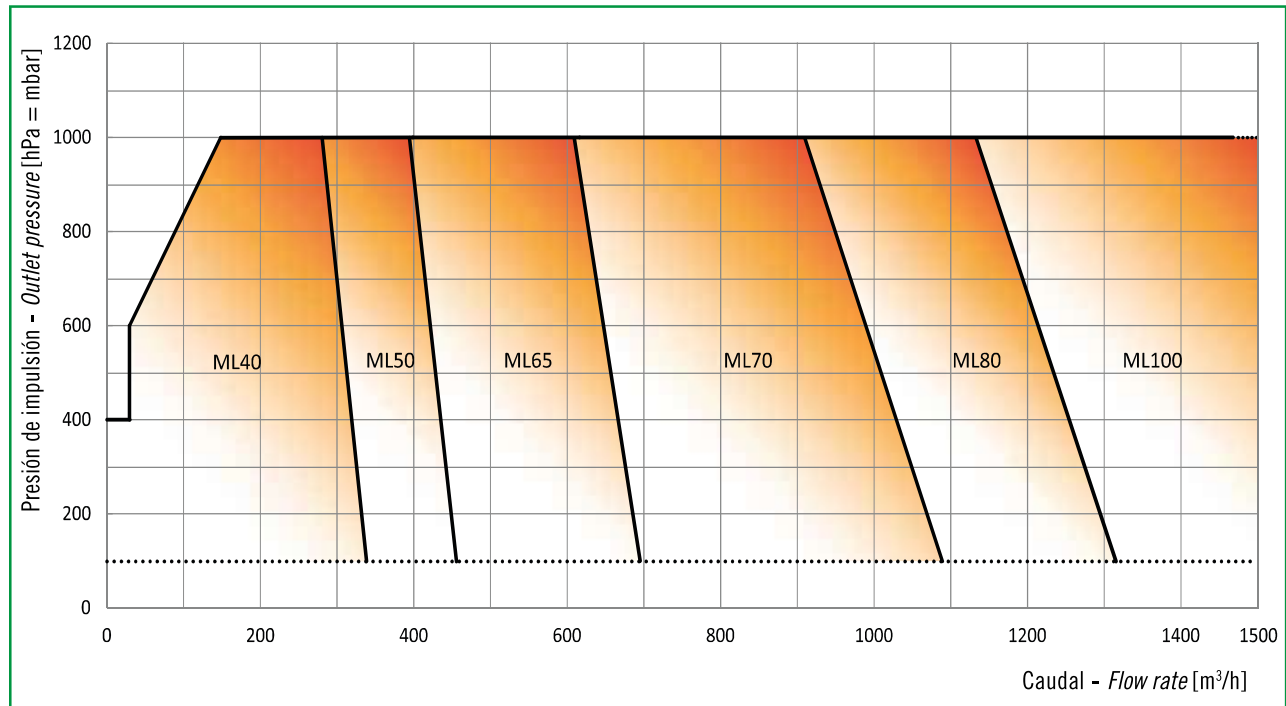

Prestaciones

Performance

Δp hPa=mbar	Tipo Soplado / <i>Blower type</i>		ML 40							ML 50								
	Motor [rev/min] / <i>Motor</i> [rpm]		1500				3000			1500				3000				
	Soplador [rev/min] / <i>Blower</i> [rpm]		1000	1250	1500	2000	2500	3000	3500	4000	1000	1250	1500	2000	2500	3000	3500	4000
200	Q	m³/h	54	78	101	147	193	240	286	332	64	96	128	190	254	317	380	443
	Δt	°C	37	32	28	28	27	26	26	26	34	30	27	24	23	24	24	24
	P abs	kW	0,8	1,0	1,2	1,6	2	2,4	2,8	3,2	1,1	1,3	1,6	2,1	2,7	3,2	3,7	4,3
	P mot	kW	1,5	1,5	2,2	2,2	3	3	4	4	1,5	2,2	2,2	3	4	4	5,5	5,5
	Lp (A)	s/c c/c	dB(A)	76	77	79	80	81	81	84	86	67	70	73	78	85	85	87
300	Q	m³/h	46	69	92	139	185	231	277	323	55	87	118	182	245	308	371	434
	Δt	°C	50	43	39	35	34	33	33	34	53	49	43	35	34	34	33	33
	P abs	kW	1	1,3	1,5	2,1	2,6	3,1	3,6	4,1	1,4	1,8	2,1	2,8	3,5	4,2	4,9	5,6
	P mot	kW	1,5	2,2	2,2	3	4	4	5,5	5,5	2,2	2,2	3	4	5,5	5,5	7,5	7,5
	Lp (A)	s/c c/c	dB(A)	78	79	80	81	82	82	84	87	68	71	74	80	86	86	88
400	Q	m³/h	39	62	85	131	178	224	270	316	48	80	111	175	237	301	364	427
	Δt	°C	67	60	52	47	44	43	43	43	74	67	59	46	45	44	43	43
	P abs	kW	1,2	1,6	1,9	2,5	3,1	3,7	4,4	5	1,7	2,1	2,6	3,4	4,3	5,2	6	6,9
	P mot	kW	2,2	2,2	3	4	4	5,5	5,5	7,5	2,2	3	4	5,5	5,5	7,5	7,5	9,2
	Lp (A)	s/c c/c	dB(A)	79	80	81	81	82	82	84	87	69	72	75	81	87	87	89
500	Q	m³/h	32	56	79	125	171	217	264	310	42	74	105	168	232	294	358	421
	Δt	°C	85	75	68	61	59	58	57	57	94	84	75	59	56	55	54	54
	P abs	kW	1,5	1,8	2,2	2,9	3,7	4,4	5,1	5,9	2	2,6	3,1	4,1	5,1	6,2	7,2	8,2
	P mot	kW	2,2	3	3	4	5,5	5,5	7,5	7,5	3	4	4	5,5	7,5	7,5	9,2	11
	Lp (A)	s/c c/c	dB(A)	79	81	81	82	82	82	84	88	72	75	77	82	87	88	90
600	Q	m³/h	27	50	73	119	165	212	258	305	37	68	100	163	226	289	353	415
	Δt	°C	107	95	84	76	72	71	70	71	112	99	90	75	70	67	65	65
	P abs	kW	1,7	2,1	2,5	3,4	4,2	5,1	5,9	6,7	2,4	2,9	3,6	4,8	6	7,1	8,3	9,5
	P mot	kW	2,2	3	4	5,5	5,5	7,5	7,5	9,2	3	4	5,5	7,5	7,5	9,2	11	15
	Lp (A)	s/c c/c	dB(A)	80	81	82	82	82	82	85	89	74	76	78	83	88	88	92
700	Q	m³/h		45	68	114	160	207	253	299		64	95	158	222	284	348	411
	Δt	°C		117	99	89	87	86	85	84		117	104	88	81	78	76	76
	P abs	kW		2,4	2,9	3,8	4,8	5,7	6,7	7,6		3,4	4,1	5,4	6,8	8,1	9,5	10,8
	P mot	kW		3	4	5,5	7,5	7,5	9,2	11		5,5	5,5	7,5	9,2	11	15	15
	Lp (A)	s/c c/c	dB(A)		80	81	82	82	82	85	89		79	80	83	89	89	93
800	Q	m³/h			63	109	155	202	248	294			91	154	217	280	343	407
	Δt	°C			117	106	101	98	97	96			127	111	101	95	92	91
	P abs	kW			3,2	4,2	5,3	6,4	7,4	8,5			4,6	6,1	7,6	9,1	10,6	12,2
	P mot	kW			4	5,5	7,5	9,2	11	11			5,5	7,5	9,2	11	15	15
	Lp (A)	s/c c/c	dB(A)			82	82	83	83	85	91			82	84	90	89	95
900 (*)	Q	m³/h				104	151	197	243	290				150	211	273	337	400
	Δt	°C				122	113	110	108	108				130	118	111	107	104
	P abs	kW				4,7	5,9	7	8,2	9,4				6,7	8,4	10,1	11,8	13,5
	P mot	kW				7,5	9,2	9,2	11	15				9,2	11	15	15	18,5
	Lp (A)	s/c c/c	dB(A)				83	83	83	85	91				89	90	90	96
1000 (*)	Q	m³/h					147	193	239	285					209	268	331	395
	Δt	°C					126	120	117	115					131	123	117	112
	P abs	kW					6,4	7,7	9	10,3					9,2	11,1	13,0	14,8
	P mot	kW					9,2	11	11	15					15	15	18,5	18,5
	Lp (A)	s/c c/c	dB(A)					82	83	85	89					90	92	97

Los valores de caudal se refieren al aire en las condiciones de aspiración de 20°C y 1013 mbar abs.

Q = caudal aspirado – Tolerancia sobre los valores de caudal: ± 5%

Δt = incremento de temperatura – Tolerancia en Δt : ± 5°C

Pabs = potencia absorbida en el eje motor – Tolerancia en Pabs: ± 5%

Pmot = potencia del motor eléctrico

Lp = nivel de presión acústica, medido en campo libre, a 1 m de distancia, según la norma EN ISO 2151, con tuberías acústicamente aisladas – Tolerancia: ± 2dB(A)

s/c = sin cabina de insonorización c/c = con cabina de insonorización

(*) = solo para servicio discontinuo. Para obtener información, póngase en contacto con el servicio de ventas.

Flow rates refer to air at the Standard suction conditions of 20°C and 1013 mbar abs.

Q = flow rate – Tolerance on flow rate values: ± 5%

Δt = temperature increase – Tolerance on Δt : ± 5°C

Pabs = absorbed power at motor shaft – Tolerance on Pabs: ± 5%

Pmot = electric motor power

Lp = Sound pressure level (SPL), measured in free field, at 1 m distance, in accordance with the Standard EN ISO 2151, without radiating noise of the pipes – Tolerance: ± 2dB(A)

s/c = without acoustic enclosure c/c = with acoustic enclosure

(*) = only for non-continuous operation. Please contact our Sales Department for any information.

Prestaciones

Performance

Δp hPa=mbar	Tipo Soplado / <i>Blower type</i>			ML 65							ML 70								
	Motor [rev/min] / <i>Motor</i> [rpm]			1500				3000			1500				3000				
	Soplador [rev/min] / <i>Blower</i> [rpm]			1000	1250	1500	2000	2500	3000	3500	4000	1000	1250	1500	2000	2500	3000	3500	4000
200	Q m ³ /h			102	150	198	294	389	485	580	676	200	268	341	486	631	775	920	1065
	Δt °C			26	25	25	24	24	24	24	24	28	25	22	21	21	21	22	22
	P abs kW			1,4	1,7	2,1	2,9	3,6	4,3	5	5,7	2,4	3	3,6	4,7	5,8	6,9	8,1	9,2
	P mot kW			2,2	2,2	3	4	5,5	5,5	7,5	7,5	3	4	5,5	7,5	7,5	9,2	11	11
	Lp (A)	s/c c/c	dB(A)	63	66	69	76	82	82	83	85	76	76	77	80	85	88	87	92
45				49	54	63	71	71	72	73	61	61	62	69	76	77	78	80	
300	Q m ³ /h			89	137	185	281	376	472	568	663	169	238	311	457	602	748	893	1039
	Δt °C			37	36	35	34	34	34	34	34	40	37	35	32	32	33	34	34
	P abs kW			1,9	2,4	2,9	3,9	4,8	5,8	6,8	7,7	3,4	4,1	4,9	6,3	7,7	9,2	10,6	12,1
	P mot kW			3	3	4	5,5	7,5	7,5	9,2	9,2	5,5	5,5	7,5	7,5	9,2	11	15	15
	Lp (A)	s/c c/c	dB(A)	64	67	71	77	84	84	85	86	77	78	78	82	86	89	88	92
45				50	55	64	72	73	73	74	62	62	63	71	77	78	79	81	
400	Q m ³ /h			79	127	175	270	366	462	557	653	144	215	288	434	580	726	872	1018
	Δt °C			52	50	48	45	45	45	45	45	59	55	51	46	44	44	44	45
	P abs kW			2,4	3	3,6	4,8	6,1	7,3	8,5	9,7	4,1	5	5,9	7,6	9,2	11,4	13,3	15,2
	P mot kW			3	4	5,5	7,5	7,5	9,2	11	15	15	5,5	7,5	9,2	11	15	18,5	18,5
	Lp (A)	s/c c/c	dB(A)	65	68	72	79	85	85	86	87	78	78	79	85	87	89	89	93
46				51	56	66	75	74	74	74	62	63	63	72	78	80	80	82	
500	Q m ³ /h			70	118	166	262	357	453	549	644	124	198	267	418	564	711	854	1000
	Δt °C			72	67	63	58	57	56	56	56	79	72	67	60	57	56	56	57
	P abs kW			2,9	3,6	4,4	5,8	7,3	8,8	10,2	11,7	4,8	5,9	7	9,2	11,5	13,8	16	18,5
	P mot kW			4	5,5	5,5	7,5	9,2	11	15	15	7,5	7,5	9,2	11	15	18,5	22	22
	Lp (A)	s/c c/c	dB(A)	66	69	72	79	86	86	87	88	78	79	80	86	88	90	90	94
46				51	56	66	75	74	75	74	63	64	64	72	79	80	81	83	
600	Q m ³ /h			63	111	158	254	350	445	541	636	102	172	244	392	540	688	836	984
	Δt °C			97	91	84	71	69	69	69	68	106	94	84	72	67	67	68	67
	P abs kW			3,4	4,3	5,1	6,8	8,5	10,2	11,9	13,6	5,5	6,8	8,2	10,9	13,5	16,2	18,9	21,6
	P mot kW			5,5	5,5	7,5	9,2	11	15	15	18,5	7,5	9,2	11	15	18,5	22	30	30
	Lp (A)	s/c c/c	dB(A)	66	70	73	80	86	86	88	90	79	80	80	86	88	90	91	96
46				51	56	67	76	75	76	74	64	64	65	73	80	80	81	84	
700	Q m ³ /h				102	150	246	341	437	533	628		156	228	375	523	670	817	964
	Δt °C				114	103	85	82	82	81	80		122	104	86	80	80	80	81
	P abs kW				4,9	5,9	7,7	9,6	11,7	13,7	15,6		7,9	9,3	12,4	15,5	18,5	21,7	24,8
	P mot kW				7,5	7,5	9,2	11	15	18,5	22		11	15	15	18,5	22	30	30
	Lp (A)	s/c c/c	dB(A)		73	73	80	86	87	88	91		77	80	86	89	91	92	98
				56	56	67	77	76	77	75	61	65	73	80	81	82	84		
800	Q m ³ /h					144	240	335	431	526	622			207	354	502	649	797	945
	Δt °C					128	104	94	93	92	92			128	102	92	92	92	93
	P abs kW					6,6	8,8	11	13,2	15,4	17,6			10,4	13,9	17,5	21	24,5	27,7
	P mot kW					9,2	11	15	18,5	18,5	22			15	18,5	22	30	30	37
	Lp (A)	s/c c/c	dB(A)			80	80	87	87	89	92			82	87	89	91	93	99
					65	67	78	78	78	76	67	74	81	81	84	85			
900 (*)	Q m ³ /h						233	329	424	520	616				334	487	631	779	926
	Δt °C						116	107	105	104	104				121	109	106	104	104
	P abs kW						9,8	12,2	14,7	17,1	19,6				16,4	19,6	23,1	26,7	30,4
	P mot kW						15	15	18,5	22	30				22	30	30	37	37
	Lp (A)	s/c c/c	dB(A)				81	87	88	91	93				87	89	91	94	100
						67	79	79	78	77			75	82	82	84	85		
1000 (*)	Q m ³ /h							321	417	513	608					465	613	761	910
	Δt °C							121	116	114	114					119	116	115	115
	P abs kW							13,5	16,2	18,9	21,6					20,6	25,2	28,9	32,9
	P mot kW							18,5	22	30	30					30	30	37	45
	Lp (A)	s/c c/c	dB(A)					87	88	92	94					90	92	94	100
							79	80	79	79					82	83	85	86	

Los valores de caudal se refieren al aire en las condiciones de aspiración de 20°C y 1013 mbar abs.

Q = caudal aspirado – Tolerancia sobre los valores de caudal: ± 5%

Δt = incremento de temperatura – Tolerancia en Δt : ± 5°C

Pabs = potencia absorbida en el eje motor – Tolerancia en Pabs: ± 5%

Pmot = potencia del motor eléctrico

Lp = nivel de presión acústica, medido en campo libre, a 1 m de distancia, según la norma EN ISO 2151, con tuberías acústicamente aisladas – Tolerancia: ± 2dB(A)

s/c = sin cabina de insonorización c/c = con cabina de insonorización

(*) = solo para servicio discontinuo. Para obtener información, póngase en contacto con el servicio de ventas.

Flow rates refer to air at the Standard suction conditions of 20°C and 1013 mbar abs.

Q = flow rate – Tolerance on flow rate values: ± 5%

Δt = temperature increase – Tolerance on Δt : ± 5°C

Pabs = absorbed power at motor shaft – Tolerance on Pabs: ± 5%

Pmot = electric motor power

Lp = Sound pressure level (SPL), measured in free field, at 1 m distance, in accordance with the Standard EN ISO 2151, without radiating noise of the pipes – Tolerance: ± 2dB(A)

s/c = without acoustic enclosure c/c = with acoustic enclosure

(*) = only for non-continuous operation. Please contact our Sales Department for any information.

Prestaciones

Performance

Δp hPa=mbar	Tipo Soplado / <i>Blower type</i>			ML 80								ML 100								
	Motor [rev/min] / <i>Motor</i> [rpm]			1500				3000				1500				3000				
	Soplador [rev/min] / <i>Blower</i> [rpm]			1000	1250	1500	2000	2500	3000	3500	4000	1000	1250	1500	2000	2500	3000	3500	4000	
200	Q m³/h			211	300	389	568	746	924	1102	1280	287	410	536	791	1053	1322	1596	1878	
	Δt °C			24	23	23	22	22	22	22	22	27	26	26	25	25	24	24	24	
	P abs kW			2,5	3,1	3,7	4,9	6,2	7,4	8,7	9,9	3,3	4,1	4,9	6,6	8,2	9,8	11,5	13,1	
	P mot kW			3	4	5,5	7,5	7,5	9,2	11	15	4	5,5	7,5	9,2	11	15	15	18,5	
	Lp (A)		s/c c/c	dB(A)		68	71	74	81	87	89	90	87	85	86	87	88	90	91	91
300	Q m³/h			185	275	364	542	720	898	1076	1255	250	373	497	751	1010	1276	1549	1828	
	Δt °C			42	40	39	38	38	37	37	37	39	38	38	36	36	36	36	36	
	P abs kW			3,5	4,2	5,1	6,7	8,4	10,1	11,8	13,5	4,6	5,7	6,8	9,1	11,4	13,7	15,9	18,2	
	P mot kW			5,5	5,5	7,5	9,2	11	15	15	18,5	5,5	7,5	9,2	11	15	18,5	22	22	
	Lp (A)		s/c c/c	dB(A)		70	73	76	82	88	89	91	90	86	87	88	89	91	92	92
400	Q m³/h			165	254	343	521	700	878	1056	1234	221	343	466	717	975	1239	1509	1786	
	Δt °C			62	57	54	50	49	49	48	48	55	53	52	49	49	48	48	47	
	P abs kW			4,3	5,4	6,4	8,5	10,7	12,8	14,9	17,1	5,8	7,3	8,8	11,7	14,6	17,5	20,4	23,3	
	P mot kW			5,5	7,5	9,2	11	15	18,5	22	30	7,5	9,2	11	15	18,5	22	30	30	
	Lp (A)		s/c c/c	dB(A)		72	75	78	83	89	89	93	92	87	88	89	90	92	92	93
500	Q m³/h			147	236	325	504	682	860	1038	1216	203	323	446	695	951	1214	1482	1757	
	Δt °C			81	75	70	63	59	58	58	58	72	68	66	62	60	60	59	59	
	P abs kW			5,2	6,4	7,9	10,3	12,9	15,6	18,1	20,7	6,9	8,6	10,4	13,9	17,3	20,8	24,3	27,7	
	P mot kW			7,5	9,2	11	15	18,5	22	30	30	9,2	11	15	18,5	22	30	30	37	
	Lp (A)		s/c c/c	dB(A)		73	75	78	84	89	90	93	93	89	90	90	91	92	93	94
600	Q m³/h			132	221	310	488	667	845	1023	1201	175	294	416	663	917	1177	1444	1717	
	Δt °C			101	94	87	79	73	71	70	70	94	88	82	74	71	70	69	69	
	P abs kW			6,1	7,6	9	12,1	15,2	18,1	21,2	24,2	8,4	10,5	12,8	16,8	21	25,2	29,4	33,6	
	P mot kW			7,5	9,2	11	15	18,5	22	30	30	11	15	18,5	22	30	30	37	45	
	Lp (A)		s/c c/c	dB(A)		73	76	78	84	90	90	94	95	91	91	91	92	93	94	95
700	Q m³/h				206	294	472	649	826	1003	1181		274	394	640	892	1151	1415	1686	
	Δt °C				113	104	94	87	82	82	81		106	98	89	83	81	80	79	
	P abs kW				8,7	10,4	13,9	17,4	20,9	24,4	27,8		12,1	14,5	19,3	24,2	29	33,8	38,6	
	P mot kW				11	15	18,5	22	30	30	37		15	18,5	30	30	37	45	55	
	Lp (A)		s/c c/c	dB(A)			76	79	85	90	91	95	96		92	93	93	94	95	96
800	Q m³/h					281	458	634	811	988	1165			374	618	869	1125	1388	1657	
	Δt °C					122	110	101	95	94	93			115	102	94	92	91	90	
	P abs kW					11,8	15,7	19,6	23,6	27,5	31,4			16,4	21,9	27,4	32,8	37,8	43,8	
	P mot kW					15	22	30	30	37	45			22	30	37	45	45	55	
	Lp (A)		s/c c/c	dB(A)				86	85	91	92	95	98			92	94	94	96	97
900 (*)	Q m³/h						444	621	797	974	1150				599	848	1102	1364	1631	
	Δt °C						125	115	109	107	107				116	106	103	101	101	
	P abs kW						17,5	21,9	26,3	30,9	35				24,4	30,6	36,7	42,8	48,9	
	P mot kW						22	30	37	37	45				30	37	45	55	75	
	Lp (A)		s/c c/c	dB(A)				90	92	92	96	99				94	95	96	98	102
1000 (*)	Q m³/h							606	782	958	1134					821	1074	1333	1598	
	Δt °C							127	122	118	116					120	115	112	111	
	P abs kW							24,1	29	33,8	38,6					33,7	40,5	47,2	54	
	P mot kW							30	37	45	55					45	55	75	75	
	Lp (A)		s/c c/c	dB(A)					92	93	97	100					95	96	99	102

Los valores de caudal se refieren al aire en las condiciones de aspiración de 20°C y 1013 mbar abs.

Q = caudal aspirado – Tolerancia sobre los valores de caudal: ± 5%

Δt = incremento de temperatura – Tolerancia en Δt : ± 5°C

Pabs = potencia absorbida en el eje motor – Tolerancia en Pabs: ± 5%

Pmot = potencia del motor eléctrico

Lp = nivel de presión acústica, medido en campo libre, a 1 m de distancia, según la norma EN ISO 2151, con tuberías acústicamente aisladas – Tolerancia: ± 2dB(A)

s/c = sin cabina de insonorización c/c = con cabina de insonorización

(*) = solo para servicio discontinuo. Para obtener información, póngase en contacto con el servicio de ventas.

Flow rates refer to air at the Standard suction conditions of 20°C and 1013 mbar abs.

Q = flow rate – Tolerance on flow rate values: ± 5%

Δt = temperature increase – Tolerance on Δt : ± 5°C

Pabs = absorbed power at motor shaft – Tolerance on Pabs: ± 5%

Pmot = electric motor power

Lp = Sound pressure level (SPL), measured in free field, at 1 m distance, in accordance with the Standard EN ISO 2151, without radiating noise of the pipes – Tolerance: ± 2dB(A)

s/c = without acoustic enclosure c/c = with acoustic enclosure

(*) = only for non-continuous operation. Please contact our Sales Department for any information.

Prestaciones

Performance

Δp hPa=mbar	Tipo Soplado / <i>Blower type</i>		ML 110								ML 125							
	Motor [rev/min] / <i>Motor</i> [rpm]		1500				3000				1500				3000			
	Soplador [rev/min] / <i>Blower</i> [rpm]		850	1250	1650	2050	2450	2850	3250	3850	850	1250	1650	2050	2450	2850	3250	3850
200	Q m/h		371	656	944	1243	1535	1822	2115	2542	558	931	1305	1678	2051	2425	2798	3358
	Δt °C		31	26	22	22	20	21	22	22	31	29	29	29	29	29	28	28
	P abs kW		4,7	6,3	8,4	9,9	11,8	13,7	15,6	18,6	6,3	8,3	10,1	12,5	14,9	17,0	19,5	23,0
	P mot kW		7,5	9,2	11	15	15	18,5	22	30	9,2	11	15	15	18,5	22	30	30
	Lp (A)	s/c	75	76	81	88	90	92	93	96	73	79	85	91	94	94	95	97
c/c		71	73	75	77	78	79	79	80	60	66	70	74	74	73	74	75	
300	Q m/h		316	602	881	1177	1476	1765	2050	2481	511	885	1258	1631	2004	2378	2751	3311
	Δt °C		46	40	35	33	32	33	34	35	39	36	35	35	35	35	35	35
	P abs kW		6,4	8,8	11,6	13,7	16,3	18,9	21,6	25,7	7,9	11	14,3	17,6	21	24,4	27,8	32,9
	P mot kW		9,2	11	15	18,5	22	30	30	37	11	15	18,5	22	30	30	37	45
	Lp (A)	s/c	77	77	82	88	91	92	94	97	74	79	86	93	95	95	96	98
c/c		72	73	75	77	78	79	79	80	62	68	72	75	74	74	75	75	
400	Q m/h		270	556	835	1127	1423	1709	2000	2429	472	841	1212	1584	1956	2330	2703	3263
	Δt °C		61	55	49	45	44	44	44	45	55	50	48	47	45	44	43	43
	P abs kW		7,9	11,1	14,6	17,4	20,8	24,2	27,6	32,7	9,9	14,4	18,5	23,6	29	32,9	37,5	44
	P mot kW		11	15	18,5	22	30	30	37	45	15	18,5	22	30	37	45	55	55
	Lp (A)	s/c	79	79	83	89	92	93	95	98	74	80	87	94	96	96	97	99
c/c		72	74	76	78	79	79	80	80	64	69	73	75	75	75	76	76	
500	Q m/h		229	513	791	1089	1384	1668	1957	2385	440	808	1176	1544	1913	2281	2649	3200
	Δt °C		75	67	60	57	58	59	59	60	71	65	62	59	59	58	58	58
	P abs kW		9,7	13,8	17,6	21,2	25,3	29,4	33,6	40,1	12,9	17,5	21,9	27,1	32,7	37,8	43,7	52,1
	P mot kW		15	18,5	22	30	37	37	45	55	18,5	22	30	37	45	45	55	75
	Lp (A)	s/c	80	80	84	89	92	93	95	98	75	81	88	95	97	97	98	100
c/c		73	75	76	78	79	80	80	80	67	71	74	76	77	77	77	78	
600	Q m/h		192	474	751	1043	1337	1621	1909	2334	412	777	1141	1505	1869	2233	2597	3143
	Δt °C		89	79	71	70	69	70	70	71	88	80	76	72	71	70	69	69
	P abs kW		12,3	16,4	20,9	25	29,8	34,7	39,6	47,1	15,6	20,7	25,9	32,2	38,5	44,8	51	60,5
	P mot kW		15	22	30	30	37	45	55	75	22	30	37	45	55	55	75	75
	Lp (A)	s/c	81	81	84	90	93	94	96	99	76	81	89	96	99	98	99	101
c/c		74	75	77	78	79	80	80	81	70	73	76	78	79	79	79	80	
700	Q m/h			439	714	1005	1296	1578	1864	2286		749	1111	1474	1837	2199	2562	3105
	Δt °C			92	86	84	82	83	83	84		97	89	84	82	81	81	81
	P abs kW			19,2	23,9	28,8	34,4	39,9	45,6	53,4		23,2	29,9	37,1	44,4	51,6	58,8	69,7
	P mot kW			30	30	37	45	55	55	75		30	37	45	55	75	75	90
	Lp (A)	s/c		82	85	90	93	95	97	100		78	83	90	96	100	98	100
c/c			76	77	79	79	81	81	82		74	76	78	81	80	80	81	
800	Q m/h				679	969	1259	1539	1824	2241			1082	1443	1804	2168	2528	3068
	Δt °C				105	97	92	92	93	93			108	97	93	93	92	92
	P abs kW				26,8	32,6	38,9	45,2	51,6	61,1			33,5	41,7	50,2	58,4	66,6	78,9
	P mot kW				37	45	55	55	75	75			45	55	75	75	90	110
	Lp (A)	s/c			86	91	94	95	97	100			91	97	101	101	100	102
c/c				78	79	80	81	82	82			77	80	82	81	81	82	
900 (*)	Q m/h					935	1224	1503	1786	2204				1414	1774	2132	2495	3034
	Δt °C					112	106	106	108	109				110	103	103	102	101
	P abs kW					34,9	42	49	56,2	67,1				47	56,1	65,3	74,4	88,2
	P mot kW					45	55	75	75	90				75	75	90	90	110
	Lp (A)	s/c				92	94	96	98	101				97	102	101	102	103
c/c					79	80	81	82	83				81	84	82	82	83	
1000 (*)	Q m/h						1190	1468	1750	2165					1739	2096	2452	2985
	Δt °C						119	119	120	120					116	113	112	111
	P abs kW						47,1	54,9	63,4	74,7					62	72,1	82,2	97,4
	P mot kW						75	75	90	90					75	90	110	132
	Lp (A)	s/c					95	97	99	102					104	102	103	104
c/c						80	81	83	83					84	83	83	84	

Los valores de caudal se refieren al aire en las condiciones de aspiración de 20°C y 1013 mbar abs.

Q = caudal aspirado – Tolerancia sobre los valores de caudal: ± 5%

Δt = incremento de temperatura – Tolerancia en Δt : ± 5°C

Pabs = potencia absorbida en el eje motor – Tolerancia en Pabs: ± 5%

Pmot = potencia del motor eléctrico

Lp = nivel de presión acústica, medido en campo libre, a 1 m de distancia, según la norma EN ISO 2151, con tuberías acústicamente aisladas – Tolerancia: ± 2dB(A)

s/c = sin cabina de insonorización c/c = con cabina de insonorización

(*) = solo para servicio discontinuo. Para obtener información, póngase en contacto con el servicio de ventas.

Flow rates refer to air at the Standard suction conditions of 20°C and 1013 mbar abs.

Q = flow rate – Tolerance on flow rate values: ± 5%

Δt = temperature increase – Tolerance on Δt : ± 5°C

Pabs = absorbed power at motor shaft – Tolerance on Pabs: ± 5%

Pmot = electric motor power

Lp = Sound pressure level (SPL), measured in free field, at 1 m distance, in accordance with the Standard EN ISO 2151, without radiating noise of the pipes – Tolerance: ± 2dB(A)

s/c = without acoustic enclosure c/c = with acoustic enclosure

(*) = only for non-continuous operation. Please contact our Sales Department for any information.

Prestaciones

Performance

Δp hPa=mbar	Tipo Soplado / Blower type			ML 150						ML 175									
	Motor [rev/min] / Motor [rpm]			1500			3000			1500				3000					
	Soplador [rev/min] / Blower [rpm]			850	1050	1250	1650	2050	2450	2850	3250	1150	1450	1750	2000	2300	2600	2800	3000
200	Q	m ³ /h		720	963	1207	1694	2181	2667	3154	3641	1419	1868	2324	2703	3159	3614	3916	4218
	Δt	°C		37	30	27	27	27	27	28	28	40	39	38	38	38	38	38	37
	P abs	kW		6,6	8,2	9,7	12,6	15,5	18,5	22,2	25,2	8,1	13,3	18,3	23,7	29,3	35,9	39,8	43,8
	P mot	kW		9,2	11	15	15	18,5	22	30	30	11	18,5	22	30	37	45	55	55
	Lp (A)	s/c	c/c	dB(A)	86	88	91	95	97	96	97	99	92	96	97	97	98	98	99
300	Q	m ³ /h		666	910	1153	1640	2127	2614	3100	3587	1342	1798	2253	2632	3082	3537	3846	4147
	Δt	°C		45	39	35	34	33	33	33	33	52	50	49	48	47	47	47	47
	P abs	kW		9,3	11,6	13,7	18,1	22,5	26,9	31	35,7	10,5	16,7	23	29,2	35,8	44	48,7	53,7
	P mot	kW		15	15	18,5	22	30	37	45	45	15	22	30	37	45	55	75	75
	Lp (A)	s/c	c/c	dB(A)	88	91	93	96	98	98	97	100	94	98	99	99	99	100	100
400	Q	m ³ /h		623	866	1110	1597	2083	2570	3056	3543	1278	1733	2189	2568	3024	3480	3781	4083
	Δt	°C		62	56	51	45	45	45	44	44	64	61	59	58	57	57	56	56
	P abs	kW		12,1	14,9	17,7	23,4	29,1	34,8	40,4	46,1	13,6	20,7	27,8	34,5	42,8	51,7	57,5	63,1
	P mot	kW		15	18,5	22	30	37	45	55	55	18,5	30	37	45	55	75	75	75
	Lp (A)	s/c	c/c	dB(A)	88	91	93	97	99	98	99	101	94	98	99	100	100	101	102
500	Q	m ³ /h		569	813	1056	1543	2030	2516	3003	3490	1226	1682	2131	2510	2966	3422	3724	4032
	Δt	°C		79	74	66	56	56	56	55	54	78	73	70	69	68	67	66	66
	P abs	kW		15,8	19,2	23	30,6	37,5	45,3	53	60,6	17	25	33,2	40,7	50,3	60,8	67,2	73,5
	P mot	kW		22	30	30	37	45	55	75	75	22	30	45	55	75	75	90	90
	Lp (A)	s/c	c/c	dB(A)	90	94	96	99	101	101	101	104	95	99	99	100	100	101	102
600	Q	m ³ /h		544	783	1023	1503	1982	2462	2941	3421	1175	1631	2087	2465	2921	3371	3679	3980
	Δt	°C		95	88	79	68	67	67	66	65	92	85	82	80	78	77	76	75
	P abs	kW		17,5	21,6	25,7	34	42,5	50,4	58,9	67,2	19,4	28,8	37,6	46,1	56,5	68,5	76	83,6
	P mot	kW		22	30	37	45	55	75	75	90	30	37	45	55	75	90	90	110
	Lp (A)	s/c	c/c	dB(A)	92	95	97	100	101	101	102	105	95	99	100	100	101	102	103
700	Q	m ³ /h		747	984	1459	1933	2408	2882	3357		1586	2042	2420	2870	3326	3634	3935	
	Δt	°C		102	92	79	78	78	76	75		99	94	91	89	87	86	85	
	P abs	kW		24,9	29,7	37,8	46,8	57,5	67,2	77		32	42	51,4	62	74	82,6	90,8	
	P mot	kW		30	37	45	55	75	90	110		45	55	75	90	110	110	132	
	Lp (A)	s/c	c/c	dB(A)	96	98	101	103	102	102	106		100	101	101	102	103	104	105
800	Q	m ³ /h				952	1424	1897	2369	2841	3313			1997	2375	2831	3287	3589	3891
	Δt	°C				108	93	91	91	89	88			106	103	100	98	97	96
	P abs	kW				33,7	44,5	55,3	66,1	76,2	87,6			47	55,8	67,4	80	89	97,9
	P mot	kW				45	55	75	90	110				75	90	110	110	132	
	Lp (A)	s/c	c/c	dB(A)			99	102	104	104	106			101	102	103	104	106	106
900 (*)	Q	m ³ /h					1384	1839	2309	2779	3249								
	Δt	°C					112	108	106	104	102								
	P abs	kW					49,4	61,8	73,9	86	98								
	P mot	kW					75	75	90	110	132								
	Lp (A)	s/c	c/c	dB(A)				105	106	106	105	106							
1000	Q	m ³ /h																	
	Δt	°C																	
	P abs	kW																	
	P mot	kW																	
	Lp (A)	s/c	c/c	dB(A)															

Los valores de caudal se refieren al aire en las condiciones de aspiración de 20°C y 1013 mbar abs.

Q = caudal aspirado – Tolerancia sobre los valores de caudal: ± 5%

Δt = incremento de temperatura – Tolerancia en Δt : ± 5°C

Pabs = potencia absorbida en el eje motor – Tolerancia en Pabs: ± 5%

Pmot = potencia del motor eléctrico

Lp = nivel de presión acústica, medido en campo libre, a 1 m de distancia, según la norma EN ISO 2151, con tuberías acústicamente aisladas – Tolerancia: ± 2dB(A)

s/c = sin cabina de insonorización c/c = con cabina de insonorización

(*) = solo para servicio discontinuo. Para obtener información, póngase en contacto con el servicio de ventas.

Flow rates refer to air at the Standard suction conditions of 20°C and 1013 mbar abs.

Q = flow rate – Tolerance on flow rate values: ± 5%

Δt = temperature increase – Tolerance on Δt : ± 5°C

Pabs = absorbed power at motor shaft – Tolerance on Pabs: ± 5%

Pmot = electric motor power

Lp = Sound pressure level (SPL), measured in free field, at 1 m distance, in accordance with the Standard EN ISO 2151, without radiating noise of the pipes – Tolerance: ± 2dB(A)

s/c = without acoustic enclosure c/c = with acoustic enclosure

(*) = only for non-continuous operation. Please contact our Sales Department for any information.

Dimensiones

Grupos estándar

ML 40 - 50 - 65 - 70 - 80 - 100 - 110

Dimensions

Standard packages

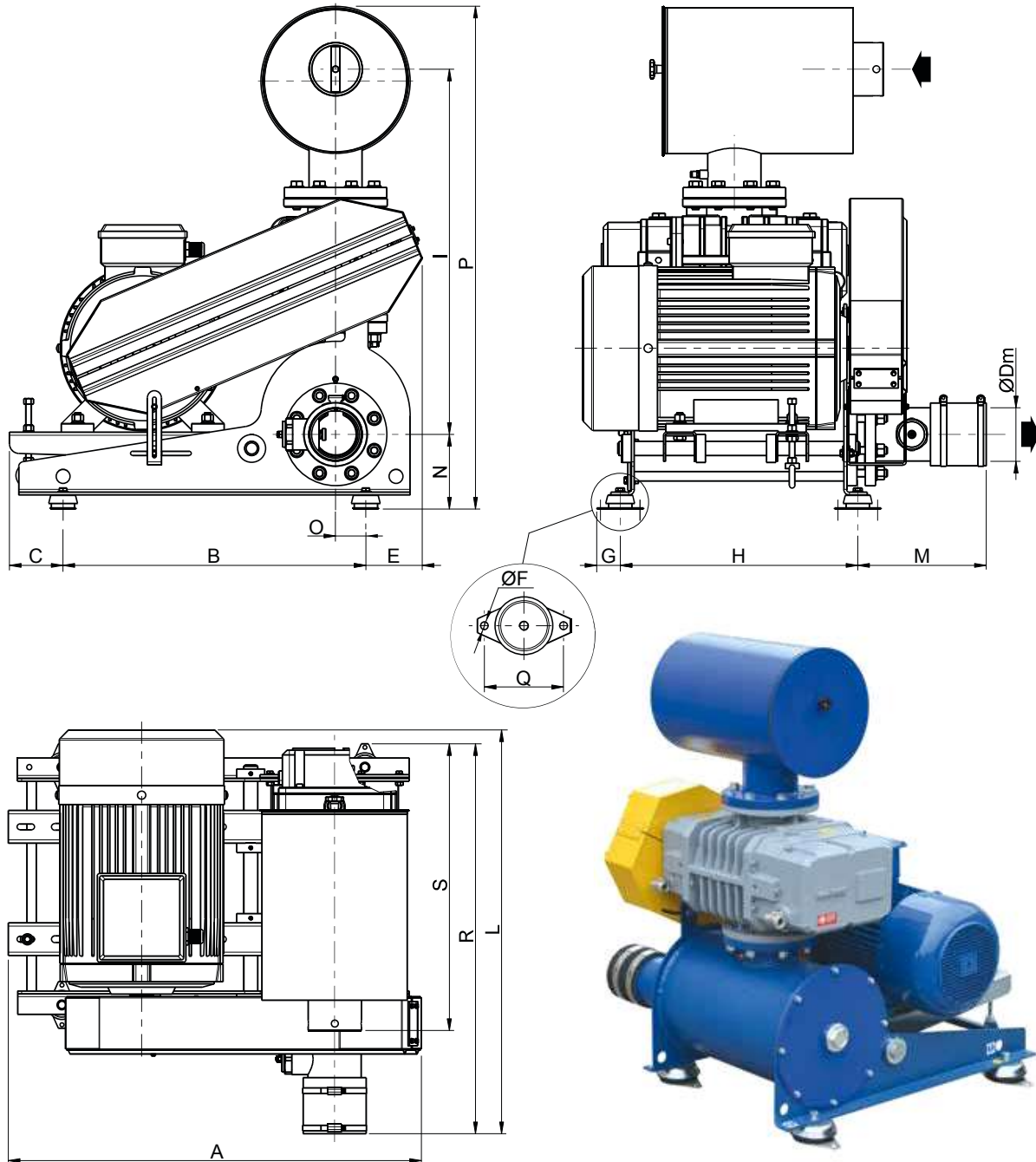

Tipo Soplado Blower Type	A	B	C	E	ØF	G	H	I	L(*)	M	N	O	P	Q	R	S	Conexión de impulsión Outlet connection ØDm	Peso Weight [kg] (**)
ML 40	810	550	114	146	8	50	430	617	846	318	160	40	891	85	798	530	74 (DN 65)	146
ML 50	887	650	115	122	8	50	510	774	844	276	160	65	1069	85	836	656	115 (DN 100)	222
ML 65	887	650	115	122	8	50	510	784	866	276	160	65	1079	85	836	615	115 (DN 100)	240
ML 70	905	650	115	140	8	50	510	840	920	276	160	65	1135	85	836	640	115 (DN 100)	282
ML 80	998	700	140	158	16	95	560	874	1040	310	220	80	1229	160	965	720	140 (DN 125)	388
ML 100	998	700	140	158	16	95	560	874	1040	310	220	80	1229	160	965	670	168 (DN 150)	430
ML 110	1010	700	140	170	16	95	560	920	1040	310	220	80	1275	160	965	700	168 (DN 150)	494

(*) La cota L se da, a título indicativo, para el motor de potencia mayor
Dimension L is given, as an indication, for the largest motor power

(**) Los pesos se entienden por grupo sin motor eléctrico
The weights are given for packages without electric motor

Dimensiones [mm] - Dimensions [mm]

Dimensiones

Grupos estándar

ML 125 - 150 - 175

Dimensions

Standard packages

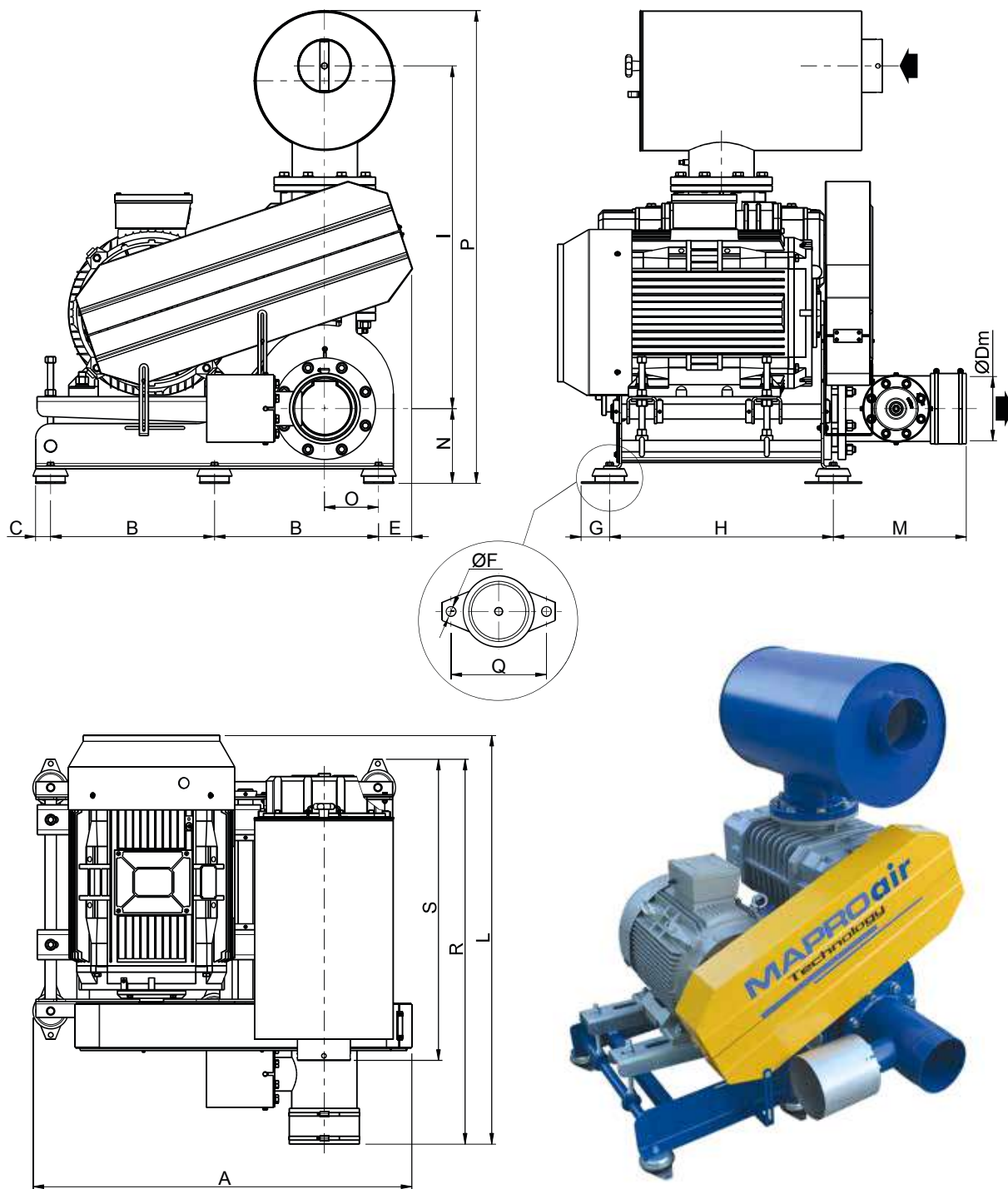

Tipo Soplado Blower Type	A	B	C	E	ØF	G	H	I	L(*)	M	N	O	P	Q	R	S	Conexión de impulsión Outlet connection ØDm	Peso Weight [kg] (**)
ML 125	1274	550	60	115	16	95	750	1147	1371	446	250	180	1582	160	1291	1010	215 (DN 200)	684
ML 150	1274	550	60	115	16	95	750	1147	1371	446	250	180	1582	160	1291	955	215 (DN 200)	714
ML 175	1270	550	60	111	16	95	750	1123	1393	446	250	180	1558	160	1291	945	215 (DN 200)	870

(*) La cota L se da, a título indicativo, para el motor de potencia mayor
Dimension L is given, as an indication, for the largest motor power

(**) Los pesos se entienden por grupo sin motor eléctrico
The weights are given for packages without electric motor

Dimensiones [mm] - Dimensions [mm]

Dimensiones

Grupos insonorizados

ML 40C - 50C - 65C - 70C - 80C - 100C - 110C - 125C - 150C - 175C

Dimensions

Soundproofed packages

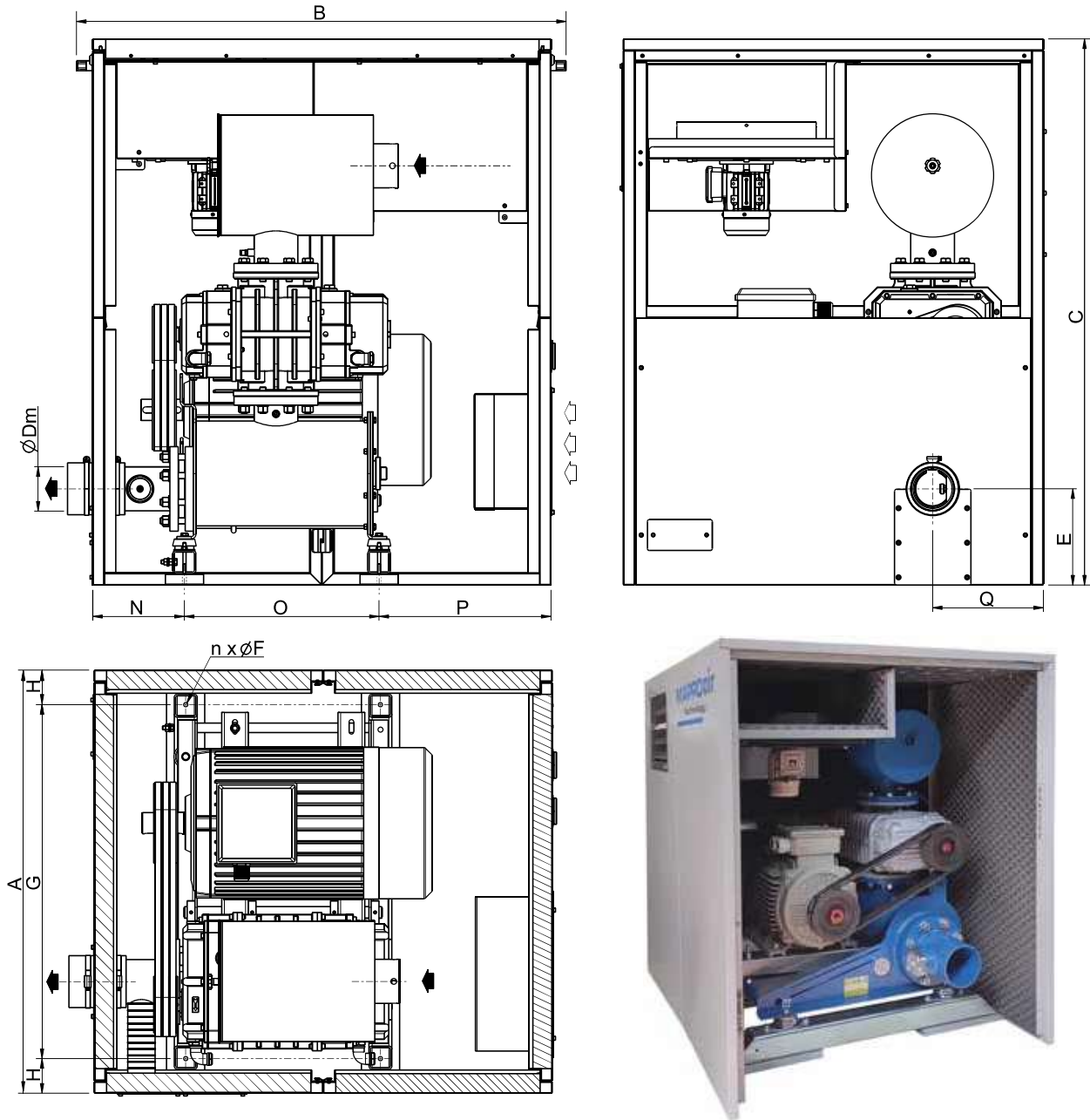

Tipo Soplado Blower Type	A	B	C	E	n x ØF	G	H	N	O	P	Q	Conexión de impulsión Outlet connection ØDm	Peso Weight [kg] (*)
ML 40 C	1000	1185	1230	250	4 x 11	820	90	240	430	430	265	74 (DN 65)	282
ML 50 C	1100	1282,5	1420	250	4 x 11	920	90	240	510	450	290	115 (DN 100)	380
ML 65 C	1100	1282,5	1420	250	4 x 11	920	90	240	510	450	290	115 (DN 100)	380
ML 70 C	1100	1282,5	1420	250	4 x 11	920	90	240	510	450	290	115 (DN 100)	380
ML 80 C	1300	1582	1530	350	4 x 11	1123	88,5	305	560	635	380	140 (DN 125)	563
ML 100 C	1300	1582	1530	350	4 x 11	1123	88,5	305	560	635	380	168 (DN 150)	605
ML 110 C	1300	1582	1530	350	4 x 11	1123	88,5	305	560	635	380	168 (DN 150)	669
ML 125 C	1500	2082	1910	380	4 x 11	1326	87,5	440	750	810	380	215 (DN 200)	1021
ML 150 C	1500	2082	1910	380	4 x 11	1326	87,5	440	750	810	380	215 (DN 200)	1051
ML 175 C	1500	2082	1910	380	4 x 11	1326	87,5	440	750	810	380	215 (DN 200)	1207

(*) Los pesos se entienden por grupo sin motor eléctrico
The weights are given for packages without electric motor

Dimensiones [mm] - Dimensions [mm]

ASPIRADORES DE LÓBULOS GIRATORIOS - Serie MLV POSITIVE DISPLACEMENT EXHAUSTERS - MLV Series

Notas técnicas de construcción de los grupos de aspiración

Grupos estándar

Los aspiradores de lóbulos giratorios MAPRO® se suministran normalmente con silenciador de impulsión integrado en la base de soporte y filtro de aspiración; la transmisión del movimiento entre la máquina y el motor eléctrico se realiza mediante correas y poleas; el tensado de las correas es automático gracias a la corredera basculante sobre la que está montado el motor eléctrico; los grupos estándar están completos con válvula de vacío, válvula de retención, soportes antivibraciones, manguito flexible de conexión en aspiración y envío, cárter de protección de la transmisión; a petición están disponibles vacuómetro y silenciador adicional para instalar en la descarga de la máquina.

Grupos insonorizados

Los grupos de aspiración se pueden suministrar completos con cabina insonorizante; las cabinas tienen su propia base, sobre la que se fija el grupo estándar, y están equipadas con ventilador de extracción de aire, vacuómetro e indicador de obstrucción del filtro para el control rápido de las condiciones de funcionamiento de la máquina; opcionalmente están disponibles termómetros, vacuostatos y termostatos y los grupos pueden equiparse con un sistema para la carga y descarga rápidas del aceite lubricante.

Aplicaciones y ventajas

Los Aspiradores de Lóbulos Giratorios MAPRO® se utilizan en todas aquellas aplicaciones en las que se requieren caudales más elevados que los de las máquinas de canal lateral y hasta 4200 m³/h, con depresión de aspiración de hasta -500 mbar g. Las aplicaciones más típicas son: transporte neumático al vacío; recuperación del subsuelo; extracción de gases inertes del depósito.

Durante el funcionamiento de los Aspiradores no hay partes entre ellas en deslizamiento. Por lo tanto, no hay fricción entre los lóbulos y entre los lóbulos y el estator y, por lo tanto, no es necesaria ninguna lubricación de las cámaras en las que se lleva a cabo el transporte de gas, que, por lo tanto, permanece totalmente libre de aceite lubricante.

Technical and constructional features of the Packages

Standard Packages

- MAPRO® Positive Displacement Exhausters are usually supplied complete with discharge silencer integrated in the supporting baseplate and with inlet filter;
- the exhausters are coupled to the electric motor via belt drives; thanks to the hinged motor support the belt drive tensioning is automatic;
- the standard packages are complete with vacuum relief valve, non-return valve, antivibration base mounts, inlet and outlet flexible hoses and safety drive guard;
- on request the packages can be supplied fitted with vacuum gauge and additional silencer to be installed at the exhauster discharge.



Soundproofed Packages

- The standard packages can be supplied complete with acoustic enclosure;
- the package is fixed on the baseplate of the acoustic enclosure; and besides the enclosure is equipped with air extraction fan, vacuum gauge and filter restriction indicator for a quick check of the working conditions of machine;
- on request the soundproofed packages can be supplied fitted with thermometers, and temperature and vacuum switches. And besides they could be equipped with system for the quick filling and draining of the lubricating oil.

Application and advantages

MAPRO® Positive Displacement Exhausters are suitable for all those applications requiring considerably higher flow rate than that which can be achieved using side channel exhausters and till 4200 m³/h, with inlet vacuum till -500 mbar g.

The most common fields of application are:

- vacuum conveying systems;
- remediation of contaminated soils;
- inert gases extraction from tanks.

There is no contact of the rotating parts during operation of the Exhausters. There is therefore no friction between the two rotors and between the rotors and the stator and thus no internal lubrication is needed. The gas moving through the machine remains uncontaminated and completely oil-free.

Los Aspiradores de Lóbulos Rotativos MAPRO® responden a las normas generales previstas por las Directivas Europeas 2006/42 (Máquinas), 2014/35 (Baja Tensión), 2014/30 (Compatibilidad Electromagnética) y a las normas armonizadas aplicables.

Ejecución de conformidad con la Directiva 2014/34/UE (ATEX)

Los grupos estándar e insonorizados para aire también están disponibles en ejecución para Zonas 2 y 22 de la Directiva Europea 2014/34/UE (ATEX).

Campo de uso

Los diagramas a continuación muestran indicativamente los campos de uso “caudal-depresión” de los diferentes modelos de máquina de la Serie MLV, que funcionan como aspiradores.

Los campos de uso se refieren al aire atmosférico a 20°C y a la depresión de aspiración, con una presión de impulsión de 1013 mbar abs.

Las tablas de las páginas siguientes detallan el rendimiento de cada modelo de aspirador.

MAPRO® Positive Displacement Exhausters meet the requirements of the European Directives 2006/42 (Machines), 2014/35 (Low Voltage), 2014/30 (Electromagnetic Compatibility) and of the applicable harmonized Standards.

Construction in conformity with the 2014/34/EU Directive (ATEX)

Standard and soundproofed packages for air are also manufactured in conformity to the requirements of the European Directive 2014/34/EU (ATEX) for Zones 2 and 22.

Range of duty

The diagrams below show, as an indication, the duty range “flow rate – inlet vacuum” for the MLV Series models, operating as exhausters.

The values of the diagrams refer to atmospheric air at the inlet vacuum and 20°C and with discharge pressure of 1013 mbar abs.

The tables on the next pages give the detailed performance of each exhauster model.

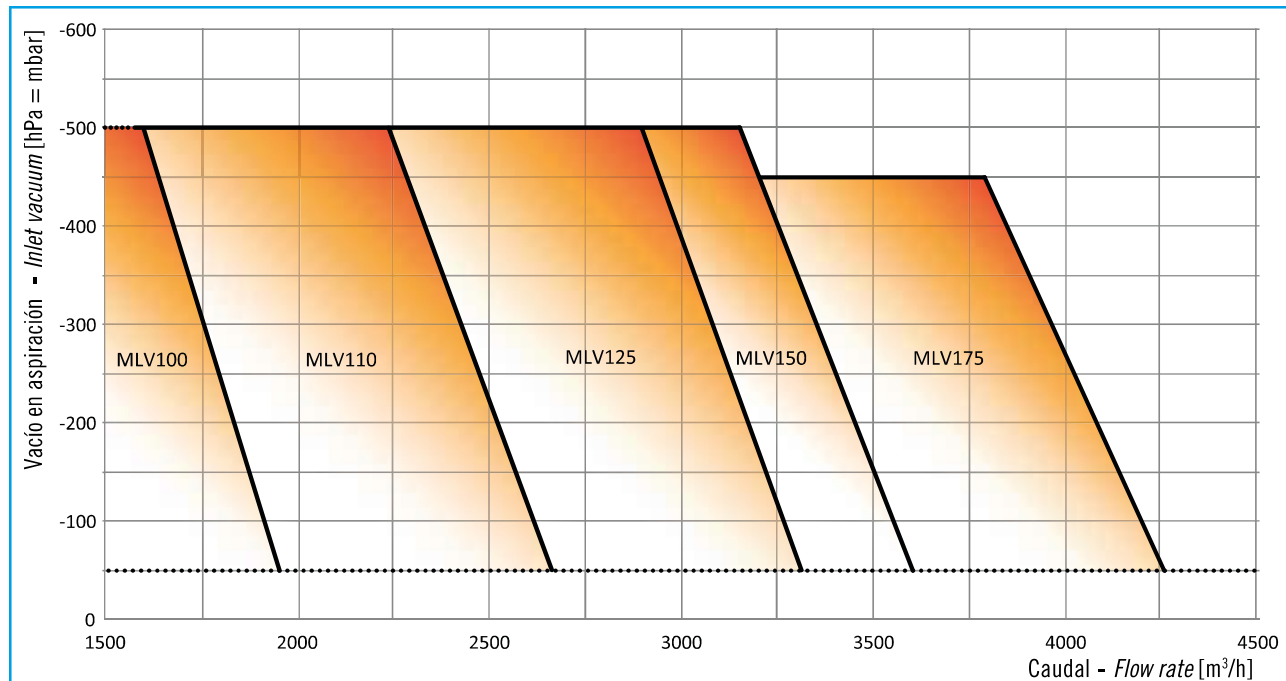
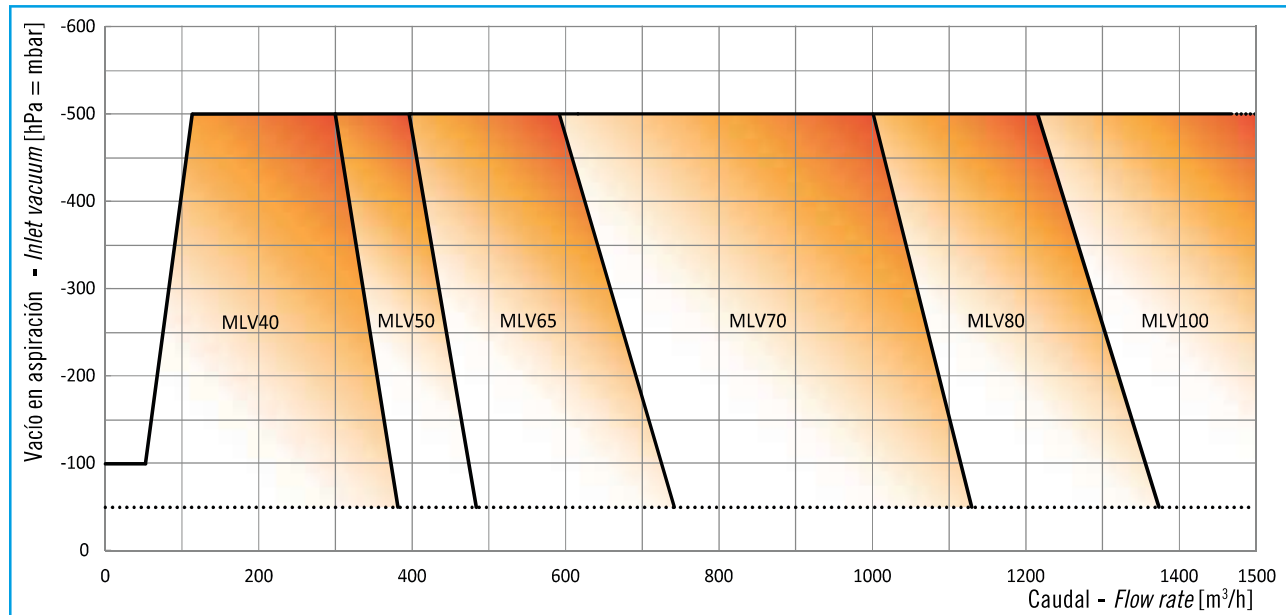

Prestaciones

Performance

Δp hPa=mbar	Tipo Aspirador/Exhauster type		MLV 40								MLV 50							
	Motor [rev/min] / Motor[rpm]		1500				3000				1500				3000			
	Aspirador [rev/min] / Exhauster[rpm]		1000	1250	1500	2000	2500	3000	3500	4000	1000	1250	1500	2000	2500	3000	3500	4000
-100	Q	m/h	96	120	139	185	232	278	324	374	107	138	168	228	289	349	410	470
	Δt	°C	67	46	36	20	15	17	18	19	62	41	31	15	10	12	13	14
	P abs	kW	0,9	1,1	1,2	1,6	1,9	2,2	2,6	2,9	0,9	1,2	1,4	1,8	2,2	2,6	2,9	3,3
	P mot	kW	1,5	1,5	2,2	2,2	3	3	4	4	1,1	1,5	2,2	2,2	3	4	4	4
	Lp (A)	s/c c/c	dB(A)	75	76	77	80	81	81	83	85	66	69	71	76	84	84	84
-150	Q	m/h	84	107	129	176	223	270	317	366	93	124	155	216	277	338	399	460
	Δt	°C	93	62	45	27	24	25	26	26	88	57	40	22	19	20	21	21
	P abs	kW	1	1,2	1,4	1,8	2,1	2,5	2,9	3,3	1,1	1,3	1,6	2	2,5	2,9	3,4	3,8
	P mot	kW	1,5	1,5	2,2	2,2	3	4	4	5,5	1,5	2,2	2,2	3	3	4	5,5	5,5
	Lp (A)	s/c c/c	dB(A)	76	77	79	80	81	81	84	86	67	70	73	78	85	85	85
-200	Q	m/h	71	95	119	167	214	262	310	358	79	110	141	203	265	327	389	451
	Δt	°C	119	77	55	34	33	33	33	34	114	72	50	29	28	28	28	29
	P abs	kW	1,1	1,3	1,5	1,9	2,4	2,8	3,2	3,7	1,3	1,6	1,9	2,4	2,9	3,4	4	4,5
	P mot	kW	1,5	2,2	2,2	3	3	4	5,5	5,5	2,2	2,2	3	3	4	5,5	5,5	5,5
	Lp (A)	s/c c/c	dB(A)	78	79	80	81	82	82	84	87	68	71	74	80	86	86	86
-250	Q	m/h	83	107	155	203	252	300	349	65	97	128	190	253	316	378	441	
	Δt	°C	93	65	44	41	41	41	41	126	88	60	39	36	36	36	36	
	P abs	kW	1,4	1,7	2,1	2,6	3,1	3,5	4,1	1,5	1,8	2,1	2,7	3,3	3,9	4,5	5	
	P mot	kW	2,2	2,2	3	4	4	5,5	5,5	2,2	2,2	3	4	4	5,5	5,5	7,5	
	Lp (A)	s/c c/c	dB(A)	80	81	81	82	82	84	87	70	72	75	81	87	87	89	91
-300	Q	m/h	70	95	144	192	241	290	339	83	115	178	241	304	368	431		
	Δt	°C	107	76	53	50	50	49	48	102	71	48	45	45	44	43		
	P abs	kW	1,5	1,8	2,3	2,8	3,3	3,9	4,5	2	2,3	3	3,6	4,3	5	5,6		
	P mot	kW	2,2	3	3	4	5,5	5,5	7,5	3	3	4	5,5	5,5	7,5	7,5		
	Lp (A)	s/c c/c	dB(A)	81	81	82	82	82	84	88	75	77	82	87	88	90	92	
-350	Q	m/h	85	134	183	232	281	331	72	104	167	231	294	358	421			
	Δt	°C	90	71	67	66	64	63	113	85	66	62	61	59	58			
	P abs	kW	2	2,6	3,2	3,7	4,3	5	2,2	2,5	3,3	4	4,8	5,5	6,3			
	P mot	kW	3	4	4	5,5	5,5	7,5	3	3	4	5,5	7,5	7,5	9,2			
	Lp (A)	s/c c/c	dB(A)	82	82	82	82	85	89	76	78	83	88	88	92	94		
-400	Q	m/h	75	124	174	223	273	322	93	157	220	284	348	411				
	Δt	°C	101	82	79	77	75	73	101	82	79	77	75	73				
	P abs	kW	2,2	2,8	3,5	4,1	4,8	5,5	2,8	3,7	4,5	5,4	6,2	7,1				
	P mot	kW	3	4	5,5	5,5	7,5	7,5	4	5,5	5,5	7,5	7,5	9,2				
	Lp (A)	s/c c/c	dB(A)	82	82	83	83	85	91	80	83	89	89	93	95			
-450	Q	m/h	115	165	214	264	314	146	210	274	338	401						
	Δt	°C	105	101	98	95	92	100	96	93	90	87						
	P abs	kW	3	3,7	4,4	5,1	5,9	3,9	4,8	5,7	6,6	7,4						
	P mot	kW	4	5,5	7,5	7,5	7,5	5,5	7,5	7,5	9,2	9,2						
	Lp (A)	s/c c/c	dB(A)	81	83	83	85	91	84	90	89	95	97					
-500 (*)	Q	m/h	106	156	206	255	305	200	263	327	391							
	Δt	°C	124	118	114	110	107	115	109	105	102							
	P abs	kW	3,2	3,9	4,7	5,4	6,3	5,2	6,2	7,2	8,2							
	P mot	kW	4	5,5	7,5	7,5	11	7,5	7,5	9,2	11							
	Lp (A)	s/c c/c	dB(A)	83	83	83	85	91	84	90	96	98						

Los valores de caudal se refieren al aire a 20°C y a la depresión de aspiración, con una presión de impulsión de 1013 mbar abs.

Q = caudal aspirado – Tolerancia sobre los valores de caudal: ± 5%

Δt = incremento de temperatura – Tolerancia en Δt : ± 5°C

Pabs = potencia absorbida en el eje motor – Tolerancia en Pabs: ± 5%

Pmot = potencia del motor eléctrico

Lp = nivel de presión sonora, medido en campo libre, a 1 m de distancia, de acuerdo con la norma EN ISO 2151, con aspiración e impulsión canalizadas y tuberías acústicamente aisladas – Tolerancia: ± 2dB(A)

s/c = sin cabina insonorizante c/c = con cabina insonorizante y silenciador adicional a la entrega

(*) = solo para servicio discontinuo. Para obtener información, póngase en contacto con el servicio de ventas.

Flow rates refer to air at the inlet vacuum and 20°C and with discharge pressure of 1013 mbar abs.

Q = flow rate – Tolerance on flow rate values: ± 5%

Δt = temperature increase – Tolerance on Δt : ± 5°C

Pabs = absorbed power at motor shaft – Tolerance on Pabs: ± 5%

Pmot = electric motor power

Lp = Sound pressure level (SPL), measured in free field, at 1 m distance, in accordance with the Standard EN ISO 2151, with inlet and discharge piped and without radiating noise of the pipes – Tolerance: ± 2dB(A)

s/c = without acoustic enclosure c/c = with acoustic enclosure and additional discharge silencer

(*) = only for non-continuous operation. Please contact our Sales Department for any information.

Prestaciones

Performance

Δp hPa=mbar	Tipo Aspirador/Exhauster type		MLV 65								MLV 70							
	Motor [rev/min] / Motor[rpm]		1500				3000				1500				3000			
	Aspirador [rev/min] / Exhauster[rpm]		1000	1250	1500	2000	2500	3000	3500	4000	1000	1250	1500	2000	2500	3000	3500	4000
-100	Q	m/h	150	198	246	342	437	534	630	725	211	285	359	507	661	811	962	1113
	Δt	°C	22	18	14	12	13	12	13	14	19	17	16	14	13	13	12	12
	P abs	kW	0,8	1,1	1,4	2	2,6	3,2	3,9	4,5	2,4	2,8	3,1	3,8	4,4	5,1	5,7	6,4
	P mot	kW	1,1	1,5	2,2	3	4	4	5,5	5,5	3	4	4	5,5	5,5	7,5	7,5	9,2
	Lp (A)	s / c c / c	dB(A)	61	64	68	74	80	80	82	83	68	71	74	81	87	90	91
-150	Q	m/h	132	180	228	324	419	517	613	708	195	266	341	492	643	795	947	1101
	Δt	°C	29	26	23	20	20	19	19	20	27	23	21	18	16	16	17	17
	P abs	kW	1,2	1,5	1,9	2,6	3,4	4,1	4,8	5,6	3	3,3	3,7	4	5,1	5,9	6,6	7,3
	P mot	kW	1,5	2,2	3	4	5,5	5,5	7,5	7,5	4	4	5,5	5,5	7,5	7,5	9,2	9,2
	Lp (A)	s / c c / c	dB(A)	63	66	69	76	82	82	83	85	70	73	76	82	88	90	92
-200	Q	m/h	113	162	210	307	401	500	596	691	174	247	323	475	627	780	934	1087
	Δt	°C	40	34	31	28	27	25	25	25	38	32	28	24	23	23	24	24
	P abs	kW	1,5	2	2,5	3,2	4,1	5	5,8	6,7	3,5	3,9	4,3	5,2	6	6,8	7,6	8,4
	P mot	kW	2,2	3	3	4	5,5	7,5	7,5	9,2	5,5	5,5	5,5	7,5	7,5	9,2	9,2	11
	Lp (A)	s / c c / c	dB(A)	64	67	71	77	84	84	85	86	72	75	78	83	89	90	93
-250	Q	m/h	95	143	192	289	384	483	579	674	156	229	306	459	613	768	923	1076
	Δt	°C	53	45	40	36	33	31	30	30	54	44	37	33	32	31	32	33
	P abs	kW	2	2,5	3	4	5	6	6,9	7,9	3,9	4,4	4,9	6	6,7	7,6	8,5	9
	P mot	kW	3	3	4	5,5	7,5	7,5	9,2	11	5,5	5,5	7,5	7,5	9,2	9,2	11	11
	Lp (A)	s / c c / c	dB(A)	65	68	72	79	85	85	86	87	72	76	79	85	90	91	94
-300	Q	m/h	76	125	174	271	366	465	563	657	216	294	446	602	757	913	1066	
	Δt	°C	62	53	49	45	43	40	39	38	57	52	48	47	48	49	49	49
	P abs	kW	2,3	2,8	3,4	4,5	5,6	6,7	7,8	8,9	5	5,7	7	7,6	8,6	9	10,4	10,4
	P mot	kW	3	4	5,5	7,5	7,5	9,2	11	11	7,5	7,5	9,2	9,2	11	11	15	15
	Lp (A)	s / c c / c	dB(A)	66	69	72	79	86	86	87	88	77	80	85	91	91	95	95
-350	Q	m/h	109	158	255	351	449	546	641	200	278	433	586	743	897	1050		
	Δt	°C	69	65	61	57	54	53	52	80	73	65	61	62	63	65	65	
	P abs	kW	3	3,7	4,8	6	7,2	8,4	9,6	5,9	6,5	7,6	9	9,6	10,5	11,6	11,6	
	P mot	kW	4	5,5	7,5	7,5	9,2	11	15	7,5	9,2	9,2	11	15	15	15	15	
	Lp (A)	s / c c / c	dB(A)	70	73	80	86	86	88	90	77	80	86	91	92	95	96	
-400	Q	m/h	93	142	239	335	433	530	625	264	419	574	730	883	1038			
	Δt	°C	90	86	80	75	71	70	69	92	82	76	77	78	79	79		
	P abs	kW	3	3,7	4,9	6,2	7,5	8,8	10,1	7	8,1	9,2	10,2	11,3	12,4	12,4		
	P mot	kW	4	5,5	7,5	7,5	9,2	11	15	9,2	11	15	15	15	15	15		
	Lp (A)	s / c c / c	dB(A)	68	73	80	86	87	88	91	80	86	92	92	96	98		
-450	Q	m/h	126	223	318	417	513	609	399	554	709	864	1019					
	Δt	°C	105	100	94	88	86	85	102	91	92	93	95					
	P abs	kW	3,8	5,2	6,6	7,9	9,3	10,7	9	10,2	11,4	12,5	13,7					
	P mot	kW	5,5	7,5	9,2	11	15	15	11	15	15	15	18,5					
	Lp (A)	s / c c / c	dB(A)	75	80	87	87	89	92	87	92	93	97	99				
-500 (*)	Q	m/h	207	302	400	497	590	539	694	849	1006							
	Δt	°C	114	108	102	101	101	114	110	110	111							
	P abs	kW	5,6	7,1	8,6	10,2	11,7	11,1	12,5	13,8	15							
	P mot	kW	7,5	9,2	11	15	15	15	15	18,5	18,5							
	Lp (A)	s / c c / c	dB(A)	81	87	88	91	93	91	94	98	101						

Los valores de caudal se refieren al aire a 20°C y a la depresión de aspiración, con una presión de impulsión de 1013 mbar abs.

Q = caudal aspirado – Tolerancia sobre los valores de caudal: $\pm 5\%$

Δt = incremento de temperatura – Tolerancia en Δt : $\pm 5^\circ\text{C}$

Pabs = potencia absorbida en el eje motor – Tolerancia en Pabs: $\pm 5\%$

Pmot = potencia del motor eléctrico

Lp = nivel de presión sonora, medido en campo libre, a 1 m de distancia, de acuerdo con la norma EN ISO 2151, con aspiración e impulsión canalizadas y tuberías acústicamente aisladas – Tolerancia: $\pm 2\text{dB(A)}$

s/c = sin cabina insonorizante c/c = con cabina insonorizante y silenciador adicional a la entrega

(*) = solo para servicio discontinuo. Para obtener información, póngase en contacto con el servicio de ventas.

Flow rates refer to air at the inlet vacuum and 20°C and with discharge pressure of 1013 mbar abs.

Q = flow rate – Tolerance on flow rate values: $\pm 5\%$

Δt = temperature increase – Tolerance on Δt : $\pm 5^\circ\text{C}$

Pabs = absorbed power at motor shaft – Tolerance on Pabs: $\pm 5\%$

Pmot = electric motor power

Lp = Sound pressure level (SPL), measured in free field, at 1 m distance, in accordance with the Standard EN ISO 2151, with inlet and discharge piped and without radiating noise of the pipes – Tolerance: $\pm 2\text{dB(A)}$

s/c = without acoustic enclosure c/c = with acoustic enclosure and additional discharge silencer

(*) = only for non-continuous operation. Please contact our Sales Department for any information.

Prestaciones

Performance

Δp hPa=mbar	Tipo Aspirador/Exhauster type		MLV 80								MLV 100							
	Motor [rev/min] / Motor [rpm]		1500				3000				1500				3000			
	Aspirador [rev/min] / Exhauster [rpm]		1000	1250	1500	2000	2500	3000	3500	4000	1000	1250	1500	2000	2500	3000	3500	4000
-100	Q	m ³ /h	247	339	432	612	801	986	1171	1356	358	488	618	872	1137	1397	1657	1915
	Δt	°C	37	28	21	16	16	18	19	20	32	26	21	16	16	17	18	19
	P abs	kW	1,2	1,9	2,6	4,1	5,6	7	8,6	10	1,8	2,7	3,6	5,4	7,2	9	10,8	12,6
	P mot	kW	2,2	3	4	5,5	7,5	9,2	11	15	3	4	5,5	7,5	9,2	11	15	18,5
	Lp (A)	s/c c/c	dB(A)	66	69	73	79	86	88	89	85	84	85	86	87	89	90	90
-150	Q	m ³ /h	223	316	409	591	781	967	1153	1339	343	471	600	852	1115	1373	1630	1883
	Δt	°C	45	37	29	25	25	26	28	29	41	35	31	26	24	25	25	26
	P abs	kW	1,5	2,3	3,2	4,8	6,5	8,1	9,8	11,5	2,3	3,2	4,4	6,4	8,5	10,6	12,7	14,7
	P mot	kW	2,2	3	4	7,5	9,2	11	15	15	3	4	5,5	9,2	11	15	18,5	18,5
	Lp (A)	s/c c/c	dB(A)	68	71	74	81	87	89	90	87	85	86	87	88	90	91	91
-200	Q	m ³ /h	200	294	388	574	764	952	1140	1328	330	452	579	828	1088	1342	1597	1846
	Δt	°C	53	46	37	34	34	35	37	38	48	43	39	34	32	32	32	33
	P abs	kW	1,8	2,7	3,6	5,4	7,3	9	10,9	12,7	2,8	4	5,2	7,8	10	12,3	14,7	17,1
	P mot	kW	2,2	4	5,5	7,5	9,2	11	15	18,5	4	5,5	7,5	11	15	15	18,5	22
	Lp (A)	s/c c/c	dB(A)	70	73	76	82	88	89	91	90	86	87	88	89	91	92	92
-250	Q	m ³ /h	178	273	367	554	747	937	1126	1316	314	437	561	802	1055	1302	1549	1790
	Δt	°C	62	55	47	43	42	44	45	46	57	52	46	43	40	38	38	38
	P abs	kW	2,2	3,2	4,2	6,2	8,2	10,2	12,3	14,3	3,4	4,7	6	8,7	11,4	14	16,7	19,3
	P mot	kW	3	4	5,5	7,5	11	15	15	18,5	5,5	7,5	7,5	11	15	18,5	22	30
	Lp (A)	s/c c/c	dB(A)	72	75	78	83	89	89	93	92	87	88	89	90	92	92	93
-300	Q	m ³ /h	155	250	345	532	727	918	1108	1299	295	417	540	779	1029	1274	1519	1759
	Δt	°C	70	64	58	53	51	52	54	55	65	60	58	52	48	48	48	48
	P abs	kW	2,6	3,7	4,8	7	9,2	11,4	13,6	15,8	3,8	5,3	6,7	9,6	12,5	15,4	18,3	21,2
	P mot	kW	4	5,5	7,5	9,2	11	15	18,5	22	5,5	7,5	9,2	15	15	18,5	22	30
	Lp (A)	s/c c/c	dB(A)	73	75	78	84	89	90	93	93	89	90	90	91	92	93	94
-350	Q	m ³ /h	125	221	317	505	701	894	1086	1278	280	402	523	761	1009	1252	1495	1733
	Δt	°C	87	78	71	65	62	63	64	65	83	78	73	67	63	63	64	64
	P abs	kW	2,9	4,1	5,3	7,9	10,2	12,6	15	17,5	3,8	5,5	7,1	10,4	13,7	17	20,3	23,6
	P mot	kW	4	5,5	7,5	11	15	18,5	18,5	22	5,5	7,5	9,2	15	18,5	22	30	30
	Lp (A)	s/c c/c	dB(A)	73	76	78	84	90	90	94	95	91	91	91	92	93	94	95
-400	Q	m ³ /h		192	289	478	677	871	1064	1258		390	509	742	982	1216	1450	1679
	Δt	°C		93	86	78	73	74	74	75		95	89	83	79	79	79	79
	P abs	kW		4,5	5,8	8,5	11,1	13,8	16,4	19,1		5,9	7,8	11,3	15	18,7	22,4	26,2
	P mot	kW		5,5	7,5	11	15	18,5	22	30		7,5	11	15	18,5	30	30	37
	Lp (A)	s/c c/c	dB(A)		75	79	85	90	91	95	96		92	93	93	94	95	96
-450	Q	m ³ /h			261	451	651	846	1041	1236			494	722	955	1183	1411	1633
	Δt	°C			101	90	85	85	85	85			105	98	95	95	95	95
	P abs	kW			6,3	9,2	12,1	15	17,9	20,7			8,1	12,2	16,3	20,4	24,5	28,5
	P mot	kW			9,2	11	15	18,5	22	30			11	15	22	30	30	37
	Lp (A)	s/c c/c	dB(A)			80	85	91	92	95	98			92	94	94	96	97
-500 (*)	Q	m ³ /h				425	626	823	1019	1215					939	1162	1384	1602
	Δt	°C				102	97	95	95	94					110	110	110	110
	P abs	kW				10	13,1	16,3	19,4	22,5					17,5	22	26,5	31
	P mot	kW				15	18,5	22	30	30					22	30	37	45
	Lp (A)	s/c c/c	dB(A)				90	92	92	96	99					95	96	98

Los valores de caudal se refieren al aire a 20°C y a la depresión de aspiración, con una presión de impulsión de 1013 mbar abs.

Q = caudal aspirado – Tolerancia sobre los valores de caudal: ± 5%

Δt = incremento de temperatura – Tolerancia en Δt : ± 5°C

Pabs = potencia absorbida en el eje motor – Tolerancia en Pabs: ± 5%

Pmot = potencia del motor eléctrico

Lp = nivel de presión sonora, medido en campo libre, a 1 m de distancia, de acuerdo con la norma EN ISO 2151, con aspiración e impulsión canalizadas y tuberías acústicamente aisladas – Tolerancia: ± 2dB(A)

s/c = sin cabina insonorizante c/c = con cabina insonorizante y silenciador adicional a la entrega

(*) = solo para servicio discontinuo. Para obtener información, póngase en contacto con el servicio de ventas.

Flow rates refer to air at the inlet vacuum and 20°C and with discharge pressure of 1013 mbar abs.

Q = flow rate – Tolerance on flow rate values: ± 5%

Δt = temperature increase – Tolerance on Δt : ± 5°C

Pabs = absorbed power at motor shaft – Tolerance on Pabs: ± 5%

Pmot = electric motor power

Lp = Sound pressure level (SPL), measured in free field, at 1 m distance, in accordance with the Standard EN ISO 2151, with inlet and discharge piped and without radiating noise of the pipes – Tolerance: ± 2dB(A)

s/c = without acoustic enclosure c/c = with acoustic enclosure and additional discharge silencer

(*) = only for non-continuous operation. Please contact our Sales Department for any information.

Prestaciones

Performance

Δp hPa=mbar	Tipo Aspirador/Exhauster type		MLV 110								MLV 125							
	Motor [rev/min] / Motor[rpm]		1500				3000				1500				3000			
	Aspirador [rev/min] / Exhauster[rpm]		850	1100	1350	1850	2350	2850	3350	3850	850	1100	1350	1850	2350	2850	3350	3850
-100	Q	m/h	486	660	832	1179	1537	1892	2253	2615	565	793	1021	1476	1931	2390	2852	3314
	Δt	°C	41	29	23	21	19	18	19	20	39	27	21	19	17	16	17	18
	P abs	kW	0,3	1,5	2,7	5,2	7,7	10,2	12,6	15,1	0,4	1,7	3,2	6	8,8	11,7	14,5	17,4
	P mot	kW	1,5	2,2	4	7,5	11	15	18,5	18,5	1,5	2,2	4	7,5	11	15	18,5	22
	Lp (A)	s / c c / c	dB(A)	86	87	88	89	91	92	92	98	72	76	80	88	94	93	95
-150	Q	m/h	430	610	783	1137	1495	1854	2212	2569	516	746	976	1435	1898	2357	2818	3278
	Δt	°C	48	36	30	28	26	25	26	27	46	34	28	26	24	23	24	25
	P abs	kW	1	2,4	3,9	6,8	9,8	12,7	15,7	18,6	1,3	2,8	4,5	7,9	11,2	14,6	18,2	21,4
	P mot	kW	1,5	3	5,5	9,2	15	18,5	22	30	2,2	4	5,5	11	15	18,5	22	30
	Lp (A)	s / c c / c	dB(A)	87	88	89	90	92	93	93	98	73	77	81	89	95	94	95
-200	Q	m/h	380	562	734	1090	1459	1817	2173	2531	468	700	933	1397	1861	2320	2790	3247
	Δt	°C	55	43	36	35	34	32	33	34	53	41	34	33	32	30	31	32
	P abs	kW	1,6	3,2	4,9	8,3	11,7	15	18,4	21,8	1,8	3,7	5,7	9,4	13,4	17,3	21,1	25
	P mot	kW	2,2	4	7,5	11	15	18,5	22	30	2,2	5,5	7,5	15	18,5	22	30	30
	Lp (A)	s / c c / c	dB(A)	88	89	90	91	93	94	94	99	73	78	82	91	96	95	96
-250	Q	m/h	340	513	687	1046	1413	1779	2135	2492	418	652	886	1354	1822	2288	2751	3214
	Δt	°C	62	50	43	42	41	40	41	42	60	48	41	40	39	38	39	40
	P abs	kW	2,2	4,2	6,1	9,9	13,8	17,6	21,5	25,3	2,6	4,8	7	11,4	15,8	20,2	24,6	29
	P mot	kW	3	5,5	7,5	15	18,5	22	30	37	4	7,5	9,2	15	22	30	30	37
	Lp (A)	s / c c / c	dB(A)	89	90	91	92	94	94	95	100	74	78	83	92	97	96	97
-300	Q	m/h	306	477	651	1006	1373	1740	2097	2450	364	596	829	1294	1759	2224	2689	3154
	Δt	°C	73	61	54	52	51	51	51	51	67	55	48	47	47	46	46	46
	P abs	kW	2,9	5	7,1	11,4	15,7	19,9	24,2	28,5	3,3	5,7	8,2	13,1	18	22,9	27,8	32,7
	P mot	kW	4	7,5	9,2	15	22	30	37	45	4	7,5	11	18,5	22	30	37	45
	Lp (A)	s / c c / c	dB(A)	91	92	92	93	94	95	96	101	75	80	84	93	98	97	98
-350	Q	m/h	268	434	610	959	1325	1689	2037	2384	318	549	781	1243	1705	2167	2629	3091
	Δt	°C	90	80	73	64	63	61	61	61	87	77	70	61	60	58	58	58
	P abs	kW	3,6	6	8,3	13	17,7	22,5	27,1	31,8	4,2	6,9	9,6	15	20,4	25,7	31,1	36,5
	P mot	kW	5,5	7,5	11	18,5	22	30	37	45	5,5	9,2	15	18,5	30	37	45	45
	Lp (A)	s / c c / c	dB(A)	93	93	93	94	95	96	97	102	76	81	85	93	98	97	99
-400	Q	m/h		397	574	916	1286	1647	1988	2332		482	712	1171	1630	2089	2549	3008
	Δt	°C		100	94	82	80	78	77	75		97	91	79	77	75	74	72
	P abs	kW		7,3	9,8	14,7	19,8	24,9	30,1	35,2		8	11	16,9	22,7	28,6	34,5	40,4
	P mot	kW		9,2	15	18,5	30	30	37	45		11	15	22	30	37	45	55
	Lp (A)	s / c c / c	dB(A)		94	95	95	96	97	98	102		82	86	94	100	98	100
-450	Q	m/h			530	879	1242	1599	1938	2277			659	1116	1572	2028	2484	2941
	Δt	°C			119	98	95	93	90	88			117	95	93	90	87	85
	P abs	kW			10,8	16,3	21,9	27,4	33	38,5			12,4	18,8	25,1	31,5	37,9	44,2
	P mot	kW			15	22	30	37	45	55			15	30	30	45	55	55
	Lp (A)	s / c c / c	dB(A)			94	96	96	98	99	103			87	95	101	99	101
-500 (*)	Q	m/h				839	1201	1560	1898	2238				1082	1537	1994	2450	2906
	Δt	°C				115	109	106	104	101				112	106	103	101	98
	P abs	kW				18,6	24,3	30,3	36,3	42,3				20,7	27,5	34,4	41,2	48,1
	P mot	kW				30	30	37	45	55				30	37	45	55	75
	Lp (A)	s / c c / c	dB(A)				95	97	98	100	104				95	102	100	102

Los valores de caudal se refieren al aire a 20°C y a la depresión de aspiración, con una presión de impulsión de 1013 mbar abs.

Q = caudal aspirado – Tolerancia sobre los valores de caudal: ± 5%

Δt = incremento de temperatura – Tolerancia en Δt: ± 5°C

Pabs = potencia absorbida en el eje motor – Tolerancia en Pabs: ± 5%

Pmot = potencia del motor eléctrico

Lp = nivel de presión sonora, medido en campo libre, a 1 m de distancia, de acuerdo con la norma EN ISO 2151, con aspiración e impulsión canalizadas y tuberías acústicamente aisladas – Tolerancia: ± 2dB(A)

s/c = sin cabina insonorizante c/c = con cabina insonorizante y silenciador adicional a la entrega

(*) = solo para servicio discontinuo. Para obtener información, póngase en contacto con el servicio de ventas.

Flow rates refer to air at the inlet vacuum and 20°C and with discharge pressure of 1013 mbar abs.

Q = flow rate – Tolerance on flow rate values: ± 5%

Δt = temperature increase – Tolerance on Δt: ± 5°C

Pabs = absorbed power at motor shaft – Tolerance on Pabs: ± 5%

Pmot = electric motor power

Lp = Sound pressure level (SPL), measured in free field, at 1 m distance, in accordance with the Standard EN ISO 2151, with inlet and discharge piped and without radiating noise of the pipes – Tolerance: ± 2dB(A)

s/c = without acoustic enclosure c/c = with acoustic enclosure and additional discharge silencer

(*) = only for non-continuous operation. Please contact our Sales Department for any information.

Prestaciones

Performance

Δp hPa=mbar	Tipo Aspirador/ Exhauster type		MLV 150							MLV 175								
	Motor [rev/min] / Motor [rpm]		1500					3000		1500				3000				
	Aspirador [rev/min] / Exhauster [rpm]		850	1050	1250	1650	2050	2450	2850	3250	1150	1450	1750	2000	2300	2600	2800	3000
-100	Q	m ³ /h	698	927	1155	1612	2069	2526	2982	3560	1472	1913	2360	2731	3178	3625	3901	4194
	Δt	°C	28	23	21	17	19	20	21	22	38	36	34	34	34	34	34	33
	P abs	kW	2	3,6	4,8	7,5	10,1	12,9	15,7	18	6,9	10	12,4	14,5	17,8	20,8	23,2	25,1
	P mot	kW	3	5,5	7,5	11	15	18,5	22	30	9,2	15	15	18,5	22	30	30	30
	Lp (A)	s/c c/c	dB(A)	84	86	89	94	96	95	96	98	91	94	95	96	96	97	98
-150	Q	m ³ /h	639	869	1099	1560	2021	2482	2943	3521	1414	1856	2303	2674	3121	3568	3844	4137
	Δt	°C	40	34	28	23	27	28	29	30	48	45	43	43	43	43	43	42
	P abs	kW	3	4,9	6,6	9,9	13,2	16,5	19,8	23,1	9	12,7	15,5	18,2	22,1	25,7	28,5	30,8
	P mot	kW	5,5	7,5	9,2	15	18,5	22	30	30	11	15	18,5	22	30	37	37	37
	Lp (A)	s/c c/c	dB(A)	86	88	91	95	97	96	97	99	92	96	97	97	98	98	99
-200	Q	m ³ /h	581	812	1044	1508	1972	2436	2899	3487	1356	1799	2247	2617	3064	3511	3787	4081
	Δt	°C	47	41	34	29	34	35	36	37	58	55	53	53	52	52	52	51
	P abs	kW	4,4	6,3	8,2	12	15,8	19,6	23,4	27,2	11,3	15,5	18,8	22,1	26,5	30,6	33,6	36,5
	P mot	kW	5,5	9,2	11	15	22	30	30	37	15	18,5	30	30	37	37	45	45
	Lp (A)	s/c c/c	dB(A)	88	91	93	96	98	98	97	100	94	98	99	99	99	100	100
-250	Q	m ³ /h	521	755	989	1457	1926	2394	2862	3441	1298	1743	2190	2560	3006	3454	3732	4025
	Δt	°C	59	52	45	39	42	44	44	45	69	66	63	63	62	62	61	61
	P abs	kW	5,7	7,9	10,1	14,5	18,9	23,3	27,7	32,1	13,4	18,2	22,2	25,7	30,8	35,3	39,2	42,1
	P mot	kW	7,5	11	15	18,5	30	30	37	45	18,5	22	30	37	37	45	55	55
	Lp (A)	s/c c/c	dB(A)	88	91	93	97	99	98	99	101	94	98	99	100	100	101	102
-300	Q	m ³ /h	462	699	935	1408	1882	2355	2828	3419	1240	1686	2134	2503	2949	3398	3675	3968
	Δt	°C	70	63	56	47	51	53	52	52	83	78	75	74	73	72	71	71
	P abs	kW	6,8	9,5	12,3	17	22	27	32	37	15,6	21	25,4	29,5	35,2	40,5	44,7	49
	P mot	kW	9,2	15	18,5	22	30	37	45	55	22	30	30	37	45	55	55	75
	Lp (A)	s/c c/c	dB(A)	90	94	96	99	101	101	101	104	95	99	99	100	100	101	102
-350	Q	m ³ /h	409	646	883	1357	1830	2304	2778	3369	1180	1626	2073	2443	2883	3336	3614	3909
	Δt	°C	91	79	72	63	67	68	68	67	97	90	87	85	83	82	81	80
	P abs	kW	7,5	10,2	13	18,8	23,7	29,5	35,1	40,6	17,8	23,7	28,6	33,3	39,6	45,4	49,6	53,4
	P mot	kW	11	15	18,5	30	30	37	45	55	22	30	37	45	55	55	75	75
	Lp (A)	s/c c/c	dB(A)	92	95	97	100	101	101	102	105	95	99	100	100	101	102	103
-400	Q	m ³ /h		596	833	1307	1782	2256	2700	3291		1567	2012	2384	2817	3276	3553	3849
	Δt	°C		100	89	79	85	86	87	86		104	99	96	94	92	91	90
	P abs	kW		10,9	13,9	19,9	25,9	31,9	38	43,9		26,5	31,9	37	43,9	50,3	55,1	60
	P mot	kW		15	18,5	30	37	45	55	55		37	45	45	55	75	75	75
	Lp (A)	s/c c/c	dB(A)		96	98	101	103	102	102	106		100	101	101	102	103	104
-450 (*)	Q	m ³ /h			730	1201	1671	2142	2613	3200			1951	2325	2750	3204	3492	3799
	Δt	°C			110	98	100	103	104	103			111	108	105	103	102	101
	P abs	kW			15,8	22,6	29,4	35,9	43	49,8			35,2	40,9	48,4	55,3	60,4	66
	P mot	kW			22	30	37	45	55	75			45	55	75	75	75	90
	Lp (A)	s/c c/c	dB(A)			99	102	104	104	104	106			101	102	103	104	106
-500 (*)	Q	m ³ /h				1164	1629	2095	2560	3148								
	Δt	°C				119	114	113	114	115								
	P abs	kW				24,5	31,9	39,3	46,7	54,1								
	P mot	kW				37	45	55	75	75								
	Lp (A)	s/c c/c	dB(A)				105	106	106	105	106							

Los valores de caudal se refieren al aire a 20°C y a la depresión de aspiración, con una presión de impulsión de 1013 mbar abs.

Q = caudal aspirado – Tolerancia sobre los valores de caudal: ± 5%

Δt = incremento de temperatura – Tolerancia en Δt : ± 5°C

Pabs = potencia absorbida en el eje motor – Tolerancia en Pabs: ± 5%

Pmot = potencia del motor eléctrico

Lp = nivel de presión sonora, medido en campo libre, a 1 m de distancia, de acuerdo con la norma EN ISO 2151, con aspiración e impulsión canalizadas y tuberías acústicamente aisladas – Tolerancia: ± 2dB(A)

s/c = sin cabina insonorizante c/c = con cabina insonorizante y silenciador adicional a la entrega

(*) = solo para servicio discontinuo. Para obtener información, póngase en contacto con el servicio de ventas.

Flow rates refer to air at the inlet vacuum and 20°C and with discharge pressure of 1013 mbar abs.

Q = flow rate – Tolerance on flow rate values: ± 5%

Δt = temperature increase – Tolerance on Δt : ± 5°C

Pabs = absorbed power at motor shaft – Tolerance on Pabs: ± 5%

Pmot = electric motor power

Lp = Sound pressure level (SPL), measured in free field, at 1 m distance, in accordance with the Standard EN ISO 2151, with inlet and discharge piped and without radiating noise of the pipes – Tolerance: ± 2dB(A)

s/c = without acoustic enclosure c/c = with acoustic enclosure and additional discharge silencer

(*) = only for non-continuous operation. Please contact our Sales Department for any information.

Dimensiones

Grupos estándar

MLV 40 - 50 - 65 - 70 - 80 - 100 - 110

Dimensions

Standard packages

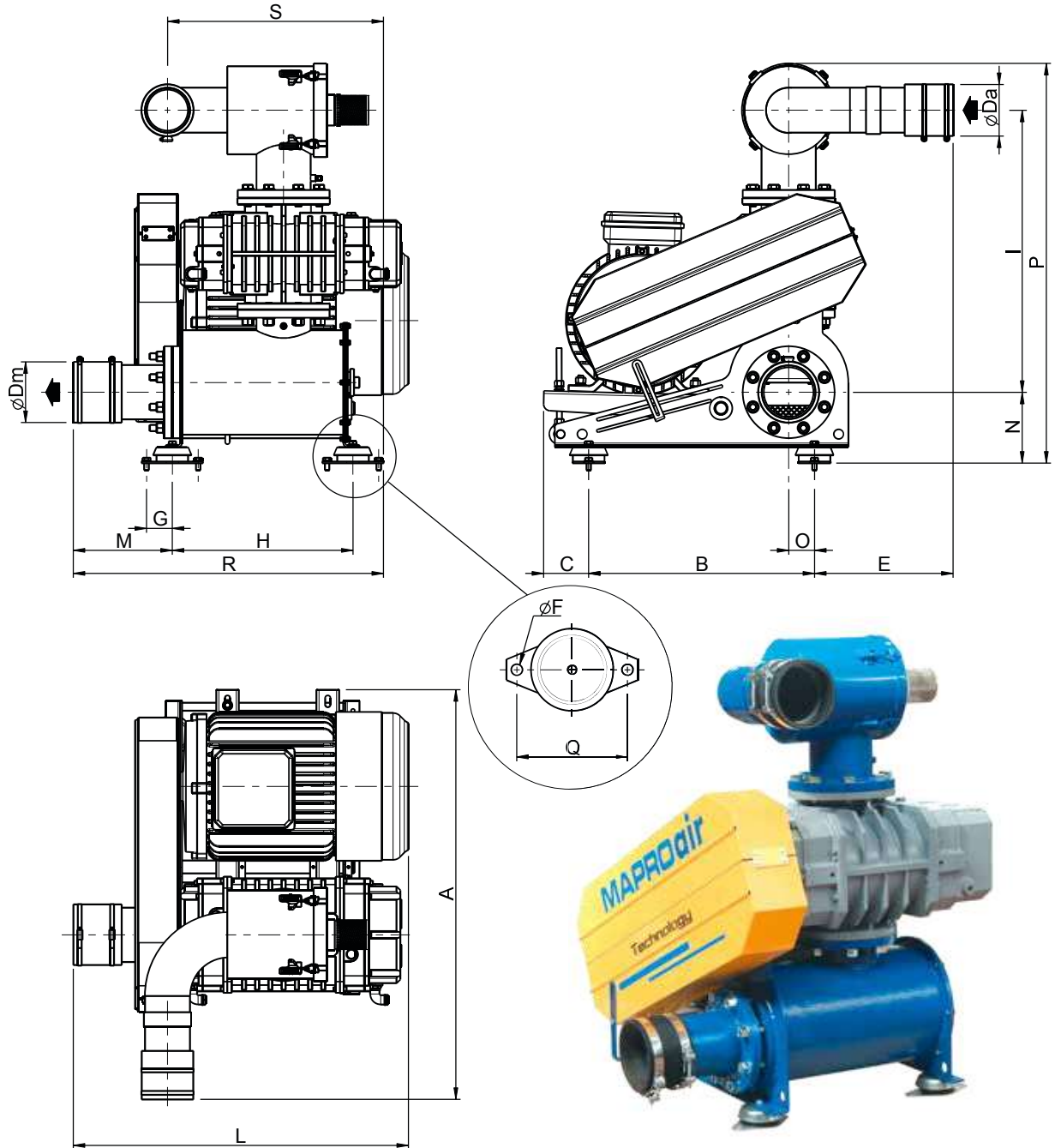

Tipo Aspirador Exhauster Type	A	B	C	E	ØF	G	H	I	L(*)	M	N	O	P	Q	R	S	Conexión aspiración Inlet connection ØDa	Conexión de impulsión Outlet connection ØDm	Peso Weight [kg] (**)
MLV 40	940	550	114	272	8	50	430	572	818	300	160	40	858	85	780	588	74 (DN 65)	74 (DN 65)	130
MLV 50	1049	650	115	295	8	50	510	774	844	286	160	65	1092	85	845	654	115 (DN 100)	115 (DN 100)	232
MLV 65	1049	650	115	295	8	50	510	784	866	286	160	65	1092	85	845	654	115 (DN 100)	115 (DN 100)	243
MLV 70	1049	650	115	295	8	50	510	799	920	296	160	65	1092	85	845	668	115 (DN 100)	115 (DN 100)	310
MLV 80	1195	700	140	378	16	95	560	874	1064	320	220	80	1246	160	980	680	140 (DN 125)	168 (DN 150)	420
MLV 100	1195	700	140	378	16	95	560	874	1064	320	220	80	1246	160	980	680	140 (DN 125)	168 (DN 150)	466
MLV 110	1293	700	140	378	16	95	560	889	1141	330	220	80	1246	160	980	680	168 (DN150)	168 (DN 150)	521

(*) La cota L se da, a título indicativo, para el motor de potencia mayor
Dimension L is given, as an indication, for the largest motor power

Dimensiones [mm] - Dimensions [mm]

(**) Los pesos se entienden por grupo sin motor eléctrico
The weights are given for packages without electric motor

Dimensiones

Grupos estándar

MLV 125 - 150 - 175

Dimensions

Standard packages

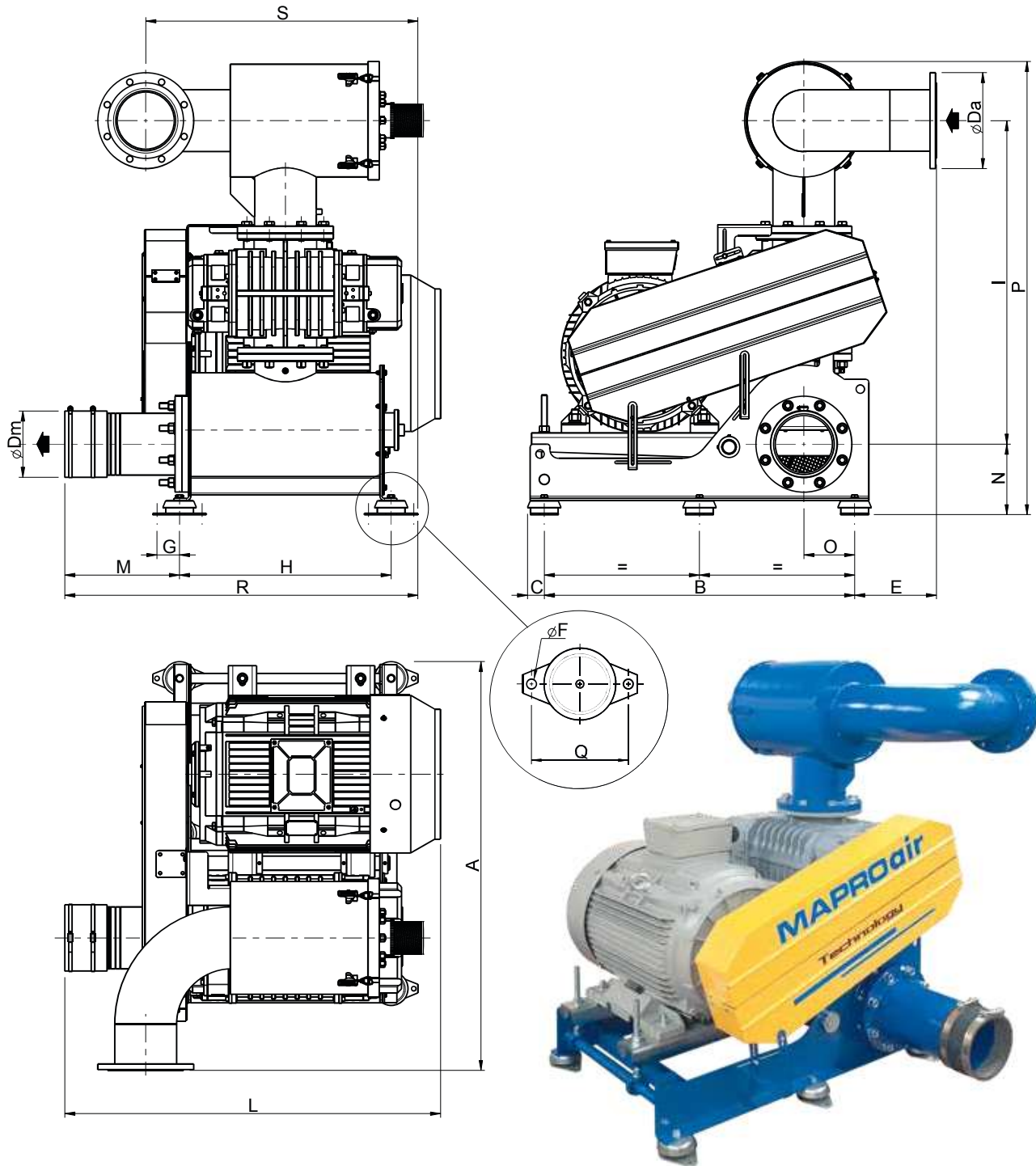

Tipo Aspirador Exhauster Type	A	B	C	E	ØF	G	H	I	L(*)	M	N	O	P	Q	R	S	Conexión aspiración Inlet connection ØDa	Conexión de impulsión Outlet connection ØDm	Peso Weight [kg] (**)
MLV 125	1457	1100	60	297	16	80	750	1147	1401	456	250	180	1602	160	1352	985	215 (DN 200)	215 (DN 200)	692
MLV 150	1457	1100	60	297	16	80	750	1147	1401	456	250	180	1602	160	1352	985	215 (DN 200)	215 (DN 200)	720
MLV 175	1457	1100	60	297	16	80	750	1123	1401	456	250	180	1602	160	1352	985	215 (DN 200)	215 (DN 200)	884

(*) La cota L se da, a título indicativo, para el motor de potencia mayor
Dimension L is given, as an indication, for the largest motor power

(**) Los pesos se entienden por grupo sin motor eléctrico
The weights are given for packages without electric motor

Dimensiones [mm] - Dimensions [mm]

Dimensiones

Grupos insonorizados

MLV 40C - 50C - 65C - 70C - 80C - 100C - 110C - 125C - 150C - 175C

Dimensions

Soundproofed packages

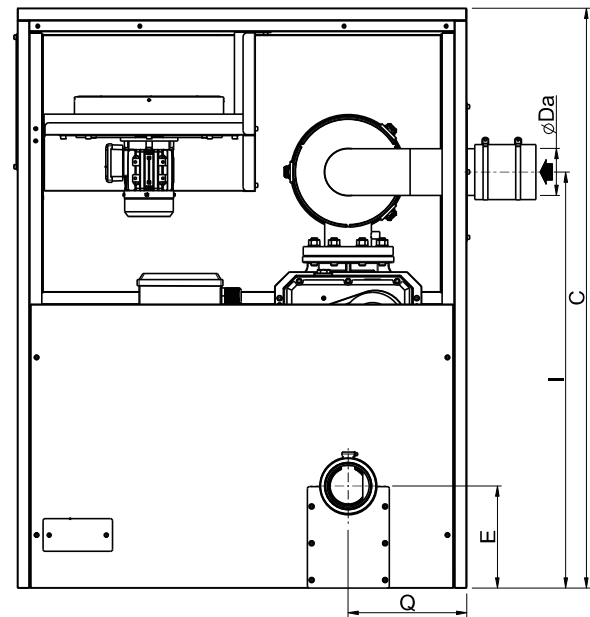
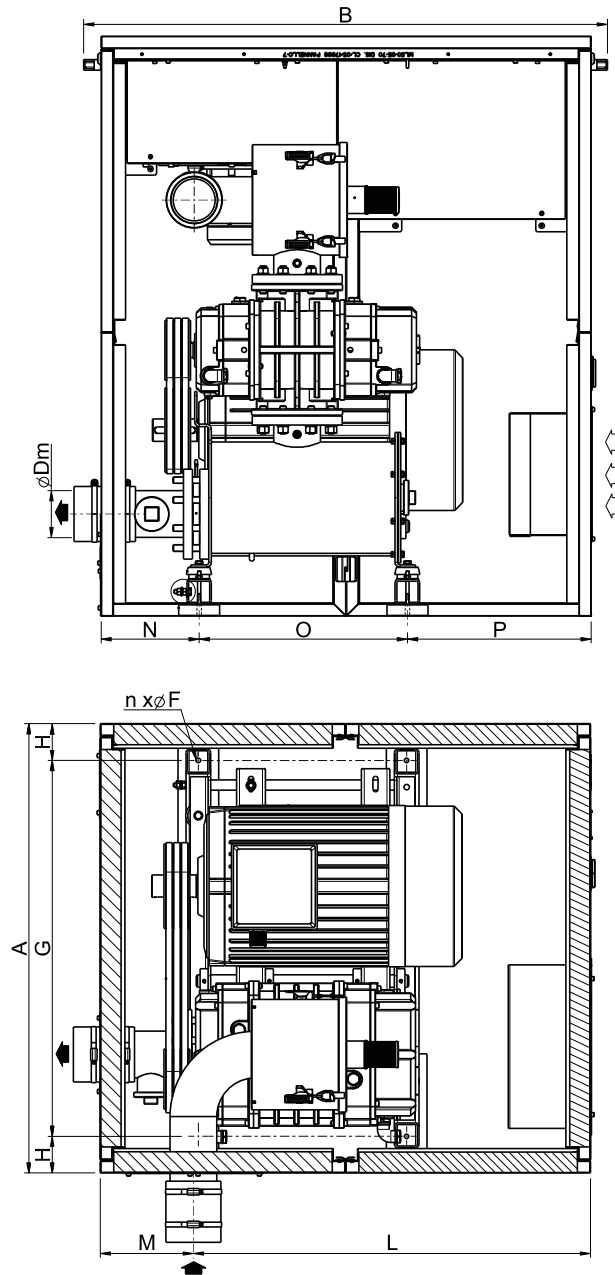

Tipo Aspirador Exhauster Type	A	B	C	E	n x ϕF	G	H	I	L	M	N	O	P	Q	Conexión aspiración Inlet connection ϕDa	Conexión de impulsión Outlet connection ϕDm	Peso Weight [kg] (*)
MLV 40 C	1000	1185	1230	250	4 x 11	820	90	842	810	290	240	430	430	265	74 (DN 65)	74 (DN 65)	266
MLV 50 C	1100	1282,5	1420	250	4 x 11	920	90	1019	972	228	240	510	450	290	115 (DN 100)	115 (DN 100)	390
MLV 65 C	1100	1282,5	1420	250	4 x 11	920	90	1019	972	228	240	510	450	290	115 (DN 100)	115 (DN 100)	401
MLV 70 C	1100	1282,5	1420	250	4 x 11	920	90	1019	972	228	240	510	450	290	115 (DN 100)	115 (DN 100)	468
MLV 80 C	1300	1582	1530	350	4 x 11	1123	88,5	1224	1210	290	305	560	635	380	140 (DN 125)	140 (DN125)	595
MLV 100 C	1300	1582	1530	350	4 x 11	1123	88,5	1224	1210	290	305	560	635	380	140 (DN 125)	168 (DN150)	641
MLV 110 C	1300	1582	1530	350	4 x 11	1123	88,5	1224	1210	290	305	560	635	380	140 (DN 125)	168 (DN150)	696
MLV 125 C	1500	2082	1910	380	4 x 11	1325	87,5	1527	1680	320	440	750	810	380	215 (DN 200)	215 (DN 200)	1029
MLV 150 C	1500	2082	1910	380	4 x 11	1325	87,5	1527	1680	320	440	750	810	380	215 (DN 200)	215 (DN 200)	1057
MLV 175 C	1500	2082	1910	380	4 x 11	1325	87,5	1527	1680	320	440	750	810	380	215 (DN 200)	215 (DN 200)	1221

(*) Los pesos se entienden por grupo sin motor eléctrico
The weights are given for packages without electric motor

Dimensiones [mm] - Dimensions [mm]

Dimensiones

Cuerpos de la máquina de eje desnudo

ML 40 BS - 50 BS - 65 BS - 70 BS - 80 BS - 100 BS - 110 BS - 125 BS - 150 BS - 175 BS

Dimensions

Bare shaft bodies

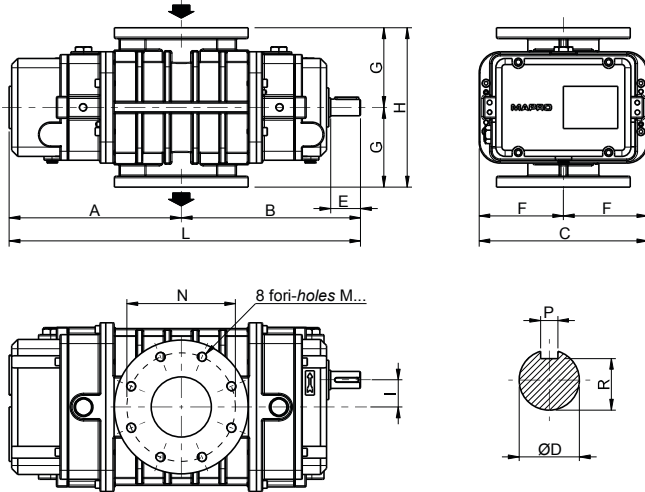

Tipo Soplador Blower Type	A	B	C	ØD	E	F	G	H	I	L	M	N	P	R	Aspiración	Impulsión Out-	Peso Weight [kg]
															EN 1092-1	let EN 1092-1	
ML 40 BS	221	232	280	28	47	140	120	240	45	453	M16	125	8	24	PN 16 DN 50	PN 16 DN 50	68
ML 50 BS	243	255	280	28	49,5	140	132	264	45	498	M16	160	8	24	PN 16 DN 80	PN 16 DN 80	71
ML 65 BS	285,5	297,5	280	28	49,5	140	132	264	45	583	M16	180	8	24	PN 16 DN 100	PN 16 DN 100	86
ML 70 BS	300	317	360	35	62	180	160	320	60	617	M16	180	10	30	PN 16 DN 100	PN 16 DN 100	128
ML 80 BS	315	337	360	35	64	180	172	344	60	652	M16	210	10	30	PN 16 DN 125	PN 16 DN 125	140
ML 100 BS	365	387	360	35	64	180	172	344	60	752	M20	240	10	30	PN 16 DN 150	PN 16 DN 150	170
ML 110 BS	371	385	463	48	80	231,5	195	390	80	756	M20	240	14	42,5	PN 16 DN 150	PN 16 DN 150	234
ML 125 BS	415	428	463	48	79	231,5	212,5	425	80	843	M20	295	14	42,5	PN 10 DN 200	PN 10 DN 200	280
ML 150 BS	470	483	463	48	79	231,5	212,5	425	80	953	M20	295	14	42,5	PN 10 DN 200	PN 10 DN 200	311
ML 175 BS	507	531	483	60	112	241,5	188	376	76	1038	M20	295	18	53	PN 10 DN 200	PN 10 DN 200	414

Dimensiones [mm] - Dimensions [mm]

Silenciador adicional en la descarga de los aspiradores MLV

La descarga de los grupos de aspiración de lóbulos giratorios siempre debe canalizarse por chimenea. Para reducir las emisiones sonoras producidas por el fluido gaseoso a la salida de los grupos MLV se puede suministrar un silenciador adicional de tipo disipativo que permite una atenuación acústica sensible gracias a la ruptura de las ondas sonoras. La descarga del silenciador suplementario podrá entonces, en función del lugar de instalación, ser canalizada a una chimenea. También disponible en versión bridada.

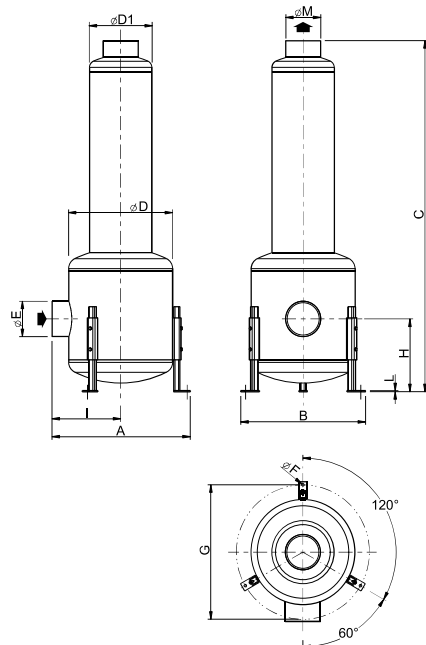

Additional silencer at the discharge of MLV exhausters

The discharge of the exhauster packages has always to be connected to a stack pipe. In order to reduce the noise produced by the pressure pulses of the fluid at the MLV packages discharge, a supplementary silencer could be supplied. This silencer allows a notable acoustic damping thanks to the breaking of the sound waves.

Depending on the installation site, the silencer outlet could then be connected to a stack pipe. Flanged version available.

Tipo Silenciador Silencer Type	Tipo Aspirador Exhauster Type	A	B	C	ØD	ØD1	ØF	G	H	I	L	ØE	ØM	Peso Weight [kg]
SM 65	MLV 40	395	384	1095	170	250	12	390	310	185	5	76	76	24
	MLV 50													
SM 100	MLV 65	535	470	1580	350	250	12	490	360	275	5	114	114	53
	MLV 70													
SM 150	MLV 80													
	MLV 100	685	600	2060	500	350	12	640	390	350	5	168	168	86
SM 200	MLV 110													
	MLV 125													
	MLV 150	785	687	2290	600	450	12	740	500	400	5	219	219	146
	MLV 175													

Dimensiones [mm] - Dimensions [mm]

